

200MHz UNIVERSAL COUNTER TIMER User Manual

MODEL 2461 Type C

Publication No. 980833-002

RACAL INSTRUMENTS

United States

(Corporate Headquarters and Service Center)
4 Goodyear Street, Irvine, CA 92618
Tel: (800) 722-2528, (949) 859-8999; Fax: (949) 859-7139
5730 Northwest Parkway Suite 700, San Antonio, TX 78249
Tel: (210) 699-6799; Fax: (210) 699-8857

Europe

(European Headquarters and Service Center)
18 Avenue Dutartre, 78150 LeChesnay, France
Tel: +33 (0)1 39 23 22 22; Fax: +33 (0)1 39 23 22 25
29-31 Cobham Road, Wimborne, Dorset BH21 7PF, United Kingdom
Tel: +44 (0) 1202 872800; Fax: +44 (0) 1202 870810
Via Milazzo 25, 20092 Cinisello B, Milan, Italy
Tel: +39 (0)2 6123 901; Fax: +39 (0)2 6129 3606
Technologie Park, Friedrich Ebert Strasse, 51429 Bergisch Gladbach, Germany
Tel: +49 (0) 2204 844200; Fax: +49 (0) 2204 844219

info@racalinstruments.com
sales@racalinstruments.com
helpdesk@racalinstruments.com
<http://www.racalinstruments.com/>



PUBLICATION DATE: November 19, 2004

Copyright 1998 by Racal Instruments, INC. Printed in the United States. All rights reserved.
This book or parts thereof may not be reproduced in any form without written permission of the publisher.

THANK YOU FOR PURCHASING THIS RACAL INSTRUMENTS PRODUCT.

For this product, or any other Racal Instruments product that incorporates software drivers, you may access our web site to verify and/or download the latest driver versions. The web address for driver downloads is:

<http://www.racalstruments.com/downloads>

If you have any questions about software driver downloads or our privacy policy, please contact us at

info@racalstruments.com.

WARRANTY STATEMENT

All Racal Instruments, Inc. products are designed and manufactured to exacting standards and in full conformance to Racal's ISO 9000/2000 procedures.

This warranty does not apply to defects resulting from any modification(s) of any product or part without Racal Instruments express written consent, or misuse of any product or part. The warranty also does not apply to fuses, software, non-rechargeable batteries, damage from battery leakage, or problems arising from normal wear, such as mechanical relay life, or failure to follow instructions.

This warranty is in lieu of all other warranties, expressed or implied, including any implied warranty of merchantability or fitness for a particular use. The remedies provided herein are buyer's sole and exclusive remedies.

For the specific terms of your standard warranty, or optional extended warranty or service agreement, contact your Racal customer service advisor. Please have the following information available to facilitate service.

1. Product serial number
2. Product model number
3. Your company and contact information

You may contact your customer service advisor by:

E-Mail:	Helpdesk@racalstruments.com	
Telephone:	+1 800 722 3262	(USA)
	+44(0) 8706 080134	(UK)
Fax:	+1 949 859 7309	(USA)
	+44(0) 1628 662017	(UK)

RETURN of PRODUCT

Authorization is required from Racal Instruments before you send us your product for service or calibration. Call your nearest Racal Instruments support facility. A list is located on the last page of this manual. If you are unsure where to call, contact Racal Instruments, Inc. Customer Support Department in Irvine, California, USA at 1-800-722-3262 or 1-949-859-8999 or via fax at 1-949-859-7139. We can be reached at: helpdesk@racalinstruments.com.

PROPRIETARY NOTICE

This document and the technical data herein disclosed, are proprietary to Racal Instruments, and shall not, without express written permission of Racal Instruments, be used, in whole or in part to solicit quotations from a competitive source or used for manufacture by anyone other than Racal Instruments. The information herein has been developed at private expense, and may only be used for operation and maintenance reference purposes or for purposes of engineering evaluation and incorporation into technical specifications and other documents which specify procurement of products from Racal Instruments.

DISCLAIMER

Buyer acknowledges and agrees that it is responsible for the operation of the goods purchased and should ensure that they are used properly and in accordance with this handbook and any other instructions provided by Seller. Racal Instruments products are not specifically designed, manufactured or intended to be used as parts, assemblies or components in planning, construction, maintenance or operation of a nuclear facility, or in life support or safety critical applications in which the failure of the Racal Instruments product could create a situation where personal injury or death could occur. Should Buyer purchase Racal Instruments product for such unintended application, Buyer shall indemnify and hold Racal Instruments, its officers, employees, subsidiaries, affiliates and distributors harmless against all claims arising out of a claim for personal injury or death associated with such unintended use.

FOR YOUR SAFETY

Before undertaking any troubleshooting, maintenance or exploratory procedure, read carefully the **WARNINGS** and **CAUTION** notices.



CAUTION
RISK OF ELECTRICAL SHOCK
DO NOT OPEN



This equipment contains voltage hazardous to human life and safety, and is capable of inflicting personal injury.



If this instrument is to be powered from the AC line (mains) through an autotransformer, ensure the common connector is connected to the neutral (earth pole) of the power supply.



Before operating the unit, ensure the conductor (green wire) is connected to the ground (earth) conductor of the power outlet. Do not use a two-conductor extension cord or a three-prong/two-prong adapter. This will defeat the protective feature of the third conductor in the power cord.



Maintenance and calibration procedures sometimes call for operation of the unit with power applied and protective covers removed. Read the procedures and heed warnings to avoid “live” circuit points.

Before operating this instrument:

1. Ensure the proper fuse is in place for the power source to operate.
2. Ensure all other devices connected to or in proximity to this instrument are properly grounded or connected to the protective third-wire earth ground.

If the instrument:

- fails to operate satisfactorily
- shows visible damage
- has been stored under unfavorable conditions
- has sustained stress

Do not operate until, performance is checked by qualified personnel.

DECLARATION OF CONFORMITY

Ser. No. CE 021

We:

Supplier's Name:

Racal Instruments Ltd.

Supplier's Address:

480 Bath Road
Slough
Berks.
SL1 6BE

declare under our sole responsibility that the following product(s):

Product Name:

2460 Series VXI module

Product Model Number(s):

2461-Cx-Cx (where x=a to f)

Product Options:

Not Applicable

to which this declaration relates conform(s) with the following standard(s) or other normative document(s):

Safety:

EN 61010-1:1993/A2:1995

EMC:

Emissions:

EN55022:1988, Class B/BSEN 55022:1995, Class B

Immunity:

EN50082-1:1992

IEC 801-2:1991/BSEN 60801-2:1993, 4kV CD, 8kV AD, performance criteria b).

IEC 801-3:1984/IEC 1000-4-3:1995, 3V/m, performance criteria b).

IEC 801-4:1988/BSEN 61000-4-4:1995, 1kV power lines, 500V signal & data lines, performance criteria b).

IEC 1000-4-5:1995, 1kV L/N-E, 500V L-N, performance criteria b).

IEC1000-4-6:1996, 3V, performance criteria b).

IEC 1000-4-11:1994, duration of dip: 1 cycle, performance criteria c).

Supplementary Information:

The products herewith comply with the requirements of the Low Voltage Directive 73/23/EEC (as amended by Directive 93/68/EEC) and the EMC Directive 89/336/EEC (as amended by Directives 92/31/EEC and 93/68/EEC) and carry the CE mark accordingly. The products were tested in a typical configuration.

Name of Authorised Signatory:
(PRINT)

C M ROBERTSON

Professional Title of Signatory:
(PRINT)

M.D.

Signature of Authorised Signatory:

 10 JUL 98

Place and Date of Issue:

Slough, Berks., England
(town, county, country) (date)

RIL 071D

Table of Contents

Chapter 1 1-1

GENERAL 1-1

Introduction 1-1

Brief Description..... 1-2

Outstanding Resolution..... 1-2

High Speed Time Measurement 1-2

Measurement Time Out 1-2

High Performance Trigger..... 1-3

Voltage Measurements 1-3

Individual Channel Filtering..... 1-3

Selectable Sensitivity 1-4

Pulse Characterization..... 1-4

Phase Measurement..... 1-4

Powerful Arming Capability..... 1-5

High Stability Time Base..... 1-5

Special Configurations 1-5

Measurement Block 1-5

Measurement Principles 1-6

Chapter 2 2-1

INSTALLATION INSTRUCTIONS..... 2-1

Unpacking and Inspection..... 2-1

Reshipment Instructions 2-1

Installation..... 2-2

Label Requirements..... 2-5

Chapter 3 3-1

THEORY OF OPERATION 3-1

Functional Systems..... 3-1

Input Channels 1 & 2 System 3-1

Input Channel 3 System..... 3-2

Measurement System 3-5

Microprocessor System 3-8

Details of the Counter	3-9
Measurement Functions	3-10
Signal Inputs	3-14
Additional Capabilities	3-14

Chapter 4	4-1
PROGRAMMING THE TYPE C FUNCTION CARD	4-1
Introduction	4-1
Default Conditions	4-1
Functional Check	4-4
INTRODUCTION	4-4
VXIBUS Communication Check.....	4-4
List of SCPI Commands.....	4-5
2461 TYPE C Commands.....	4-10
CALCULATE Subsystem	4-10
MeASUREMENT Subsystem.....	4-12
CONFigure Subsystem	4-12
FETCh Subsystem.....	4-24
MEASure Subsystem	4-27
READ Subsystem	4-38
INPut Subsystem	4-39
OUTPut Subsystem	4-50
SENSE SUBSYSTEM.....	4-51
SOURCE SUBSYSTEM	4-61
TEST SUBSYSTEM.....	4-62
TRIGGER SUBSYSTEM	4-68
2461 TYPE C-Specific Error Messages.....	4-75
Examples Of SCPI Commands Used To Manipulate The Instrument.....	4-75
Selecting The Counter Function Card.....	4-76
Preparation For Measurement.....	4-76
Triggering And Retrieving Measurements.....	4-77
BASICS	4-78
MULTIPLE MEASUREMENTS	4-78
AUTOMATIC RESOLUTION.....	4-79

Chapter 5	5-1
USING THE VXI plug&play INSTALL DISKS	5-1
Operating The VXI <i>plug&play</i> Install Disk.....	5-1

Using The Soft Front Panel..... 5-1
Arm Source Configuration..... 5-5
Configure Inputs..... 5-6
Select Reference 5-8
Configure Math Function..... 5-9
About..... 5-10

Chapter 6 6-1
PERFORMANCE VERIFICATION AND ADJUSTMENTS 6-1
Introduction 6-1
Test Equipment Required 6-1
Input 1 Sensitivity Test..... 6-2
Input 2 Sensitivity Test..... 6-4
Input 3 Performance Verification..... 6-6
Time Interval 1:2 Test 6-8
Totalize 1 by 2 Test..... 6-10
Ratio 1:2 Test..... 6-11
Trigger Level Accuracy Test 6-12
Functional Checks 6-14
Input 1 Filter Check..... 6-14
Input 2 Filter Check..... 6-15
Input 1 Attenuator Check 6-17
Input 2 Attenuator Check 6-18
Hysteresis Check for Input 1 6-19
Hysteresis Check for Input 2 6-19
Calibration, External Standard Output (2461-Ce and 2461-Cf) 6-20

Chapter 7 7-1
PRODUCT SUPPORT 7-1
Product Support 7-1
Reshipment Instructions 7-1

Appendix A: SPECIFICATIONS..... A-1

Appendix B: APPLICATION NOTES..... B-1

List of Figures

Figure 1-1, Universal Counter Timer 2461 Type C Function Card	1-1
Figure 1-2, High Speed Time Measurement.....	1-2
Figure 1-3, High Performance Trigger	1-3
Figure 1-4, Selectable Sensitivity	1-4
Figure 1-5, Pulse Characterization	1-4
Figure 1-6, Powerful Arming Capability	1-5
Figure 1-7, Measurement Block.....	1-7
Figure 2-1, The Universal Counter Timer	2-2
Figure 2-2, Removing the Screws from the Module.....	2-3
Figure 2-3, Removing the Front Panel.....	2-3
Figure 2-4, The 2461 Type C.....	2-4
Figure 2-5, Tightening the Four Screws.	2-4
Figure 2-6, The Racal Instruments Label	2-5
Figure 3-1, Inputs 1 &2	3-4
Figure 3-2, Measurement Block.....	3-7
Figure 3-3, Block diagram of processor system.....	3-9
Figure 5-1, 2461-C Front Panel	5-2
Figure 5-2, Configure Arming secondary panel	5-5
Figure 5-3, Configure Input secondary panel	5-6
Figure 5-4, Select Reference.....	5-8
Figure 5-5, Configure Math Function secondary panel.....	5-9
Figure 5-6, About secondary panel.....	5-10
Figure 6-1, Input 1 Low Frequency Sensitivity Test Configuration	6-2
Figure 6-2, Input 2 Low Frequency Sensitivity Test Configuration	6-4
Figure 6-3, Time Interval 1-2 Test Configuration	6-8
Figure 6-4, Totalize 1 by 2 Test Configuration.....	6-10
Figure 6-5, Ratio 1 : 2 Test Configuration.....	6-11
Figure 6-6 Input 1 Trigger Level Test Configuration	6-12
Figure 6-7, Input 1 Filter Check Configuration	6-14
Figure 6-8, Input 2 Filter Check Configuration	6-15
Figure 6-9, Input 1 X10 Attenuator Check Configuration.....	6-17
Figure 6-10, Input 2 X10 Attenuator Check Configuration.....	6-18

Figure 6-11, External Standard Output 6-20

List of Tables

Table 6-1, Input 1 Sensitivity Low Frequency Test 6-2
Table 6-2, Input 1 Sensitivity high Frequency Performance Limits 6-3
Table 6-3, Input 2 Sensitivity Low Frequency Tests 6-5
Table 6-4, Input 2 Sensitivity High Frequency Tests 6-5
Table 6-5, Time Interval 1-2 Test Performance Limits 6-9

This page was left intentionally blank.

Chapter 1

GENERAL

Introduction

The type C card is a high performance universal counter designed to be used with the innovative RACAL Instruments 2460 Series, VXI Modules.

The Counter card offers eleven automatic measurement functions, including phase, pulse, peak, rise/fall time, time interval and ratio measurement, all with extremely high resolution.

To perform high performance measurement, the Counter card includes one filter per channel and a selectable hysteresis.

The Cd card does not include an oscillator. The Ce has a TCXO oscillator and the Cf card a high performance OCXO oscillator.

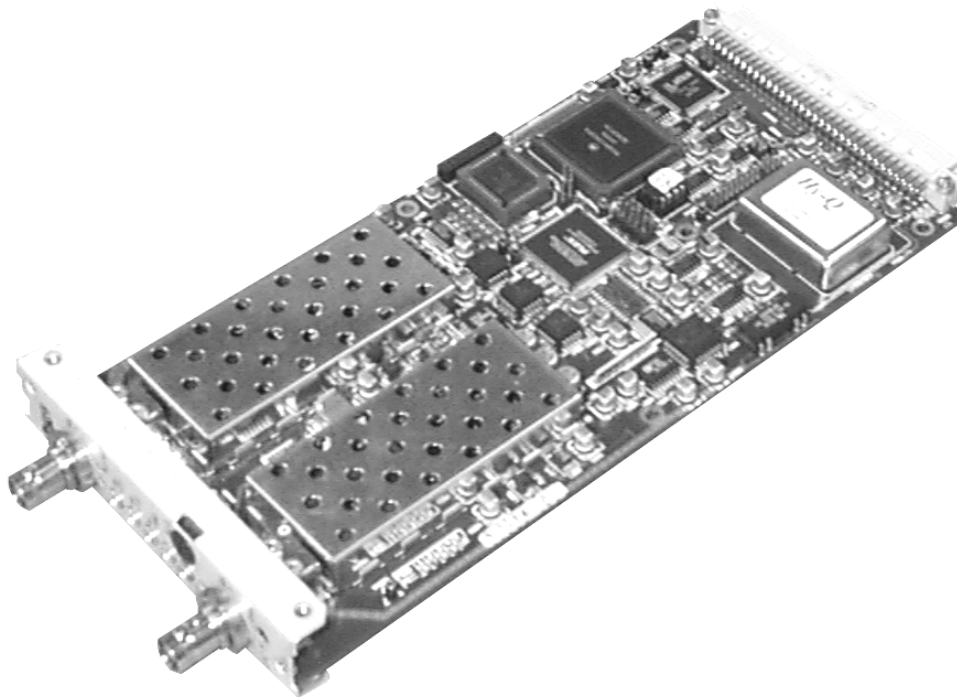

**Figure 1-1, Universal Counter Timer
2461 Type C Function Card**

Brief Description

The 2461 Type C card is a member of the 2460 series instruments. The 2461 Type C card is a high performance Universal Counter (UCT) offering eleven automatic measurement functions :

- Frequency
- Period
- Time Interval
- Time Interval Delay
- Rise Time
- Fall Time
- Pulse Width
- Frequency Ratio channel 1 to 2 (Ratio 3 to 2 optional)
- Totalize
- Phase
- Voltage (Voltage High, Voltage Low and Average Voltage)

Outstanding Resolution

The 2461 Type C card offers 200 MHz frequency range measurements with a resolution going up to 10 digits per second. In time interval the resolution is 1 ns in single shot and 100 ps in average mode.

High Speed Time Measurement

By using Timing Error Correction (TEC) in combination with traditional recipromatic techniques, measurement time may be minimized without any compromise in performance.

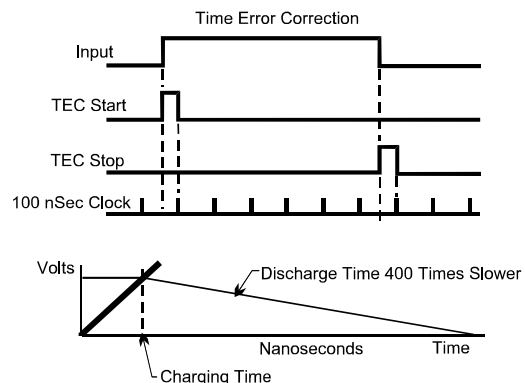

Figure 1-2, High Speed Time Measurement

Measurement

Programmable measurement Time-out helps the user to optimize system performance when of the input signal is missing

Time Out

system performance when of the input signal is missing.

High Performance Trigger

In Manual mode, the trigger level is programmable from -5.1 V to $+5.1$ V with the exceptional resolution of 2.5 mV.

An automatic trigger mode is also available covering a frequency range of DC and 50 Hz to 200 MHz.

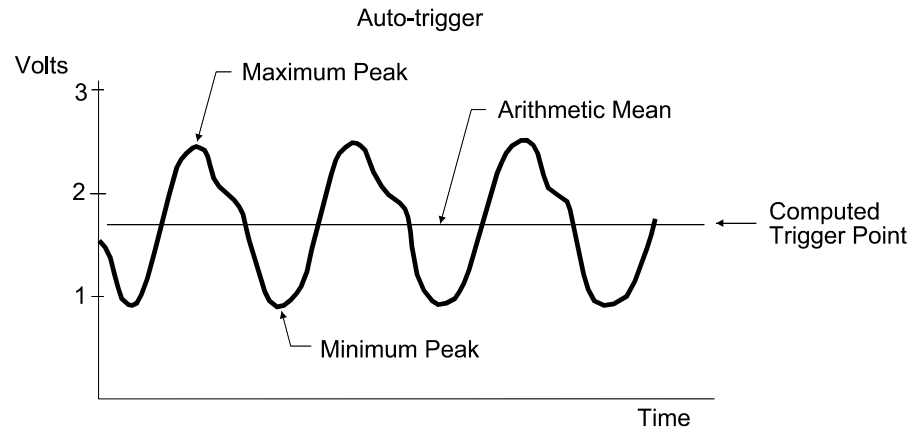

Figure 1-3, High Performance Trigger

Voltage Measurements

Automatic triggering is used to establish the peak DC voltages for setting trigger points. This feature is used to measure Voltage High, Voltage Low and Average Voltage.

Individual Channel Filtering

The 2461 Type C card offers independent 50 kHz low pass filters on each channel to allow measurements in noisy configurations.

Selectable Sensitivity

The sensitivity of the counter can be decreased to perform measurement on a low level signal with noise. This characteristic is very important for system applications, requiring measurement of signals in noisy configurations.

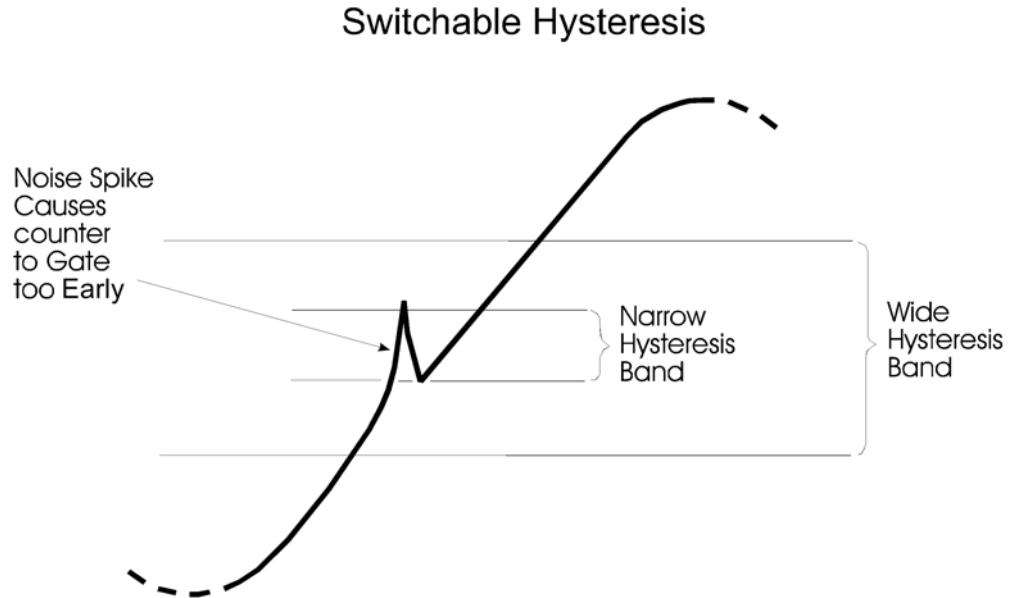

Figure 1-4, Selectable Sensitivity

Pulse Characterization

The 2461 Type C board provides automatic pulse characterization including Rise time, Fall time and pulse Width measurements.

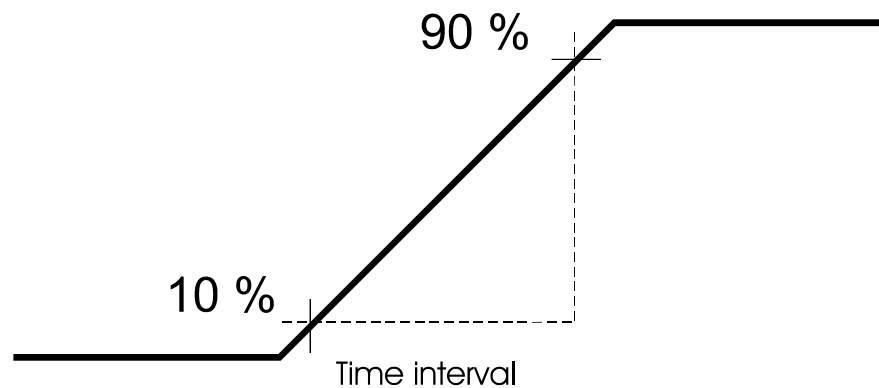

Figure 1-5, Pulse Characterization

Phase Measurement

Phase measurements are performed automatically.

Powerful Arming Capability

The 2461 Type C card offers powerful arming capability. Different modes are provided with the ability to select the arming source among the external arming input and the VXI TTLtrig lines.

Figure 1-6, Powerful Arming Capability

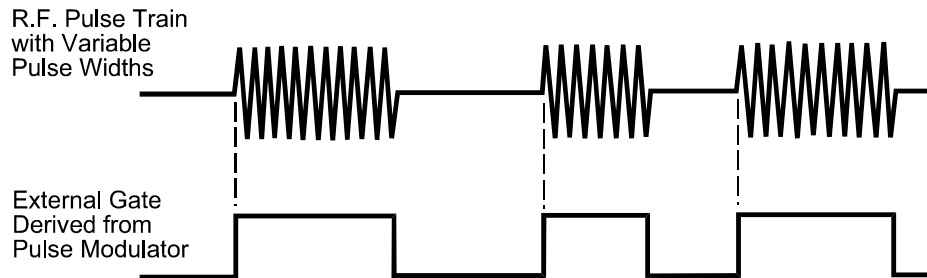

High Stability Time Base

Counter measurement stability can be improved by using an external clock or an optional internal high stability time base. Two types of internal time base are optional:

- TCXO (Ce card)
- OCXO (Cf card)

Special Configurations

The Cd, Ce and Cf cards are fitted with additional internal connectors for future applications.

Measurement Block

The measurement block is mainly implemented with an Altera Erasable Programmable logic Device (EPLD). The Timing Error Correction (TEC) circuit is external to this.

Referring to the block diagram Figure 1-7, the measurement block consists of a high speed front end which takes in Inputs 1 & 2 after conditioning by the input amplifiers. This front end connects to the microprocessor data bus to allow the micro to configure the measurement block for the type of measurement to be taken. The micro also drives the measurement process by controlling the arming of the start and stop of the measurement.

After a measurement has taken place, the micro reads the values in the various counting chains via the data bus. The measurement block uses interrupts to communicate the various events that occur in the measurement block.

Measurement Principles

The measurement technique employed is known as the recipromatic measurement technique. In this technique the signal and reference are counted simultaneously. This has the advantage that for signals of less than 10 MHz, accuracy is maintained because of the large number of counts in the reference counter. In addition the opening and closing of the gate is synchronized to the signal which, together with the Timing Error Correction (TEC) circuit allows higher resolution equivalent to a 1GHz reference.

In this system, the first edge of the incoming frequency to be measured (after the μ P has armed the start of measurement), opens the gate and simultaneously allows the signal through to the input 1 counting chain and the frequency reference through to the reference counting chain. Both signals are now counted for the duration of the gate time. The μ P determines the length of the gate time using its on-board timer, which is set by the operator.

At the end of the gate time, the μ P arms the end of measurement and the next edge of the input signal closes the gate and the two counting chains stop counting.

In the above description, there are two points at which resolution is limited by the 10 MHz reference, the opening of the gate and the closing. To overcome this limitation, the time between the signal opening the gate and the next edge of the reference is detected by logic gates in the front end and a pulse whose width is proportional to this time is generated. This pulse is then used to charge a capacitor with a constant current source so the charge on the capacitor is proportional the time error. The charge is then discharged at much slower rate and while this is going on the reference is counted in the start counting chain. When the capacitor is discharged then the count in the start counting chain represents the error between the opening of the gate and the next counting edge of the reference (see Figure 1-7).

This process is repeated at the closure of the gate by a separate TEC and counting circuit (the stop counting chain).

After the measurement results have been read out of all counters, calibrated pulses, derived from the reference, are fed to the TEC circuits. This is done for two pulse widths for both start and stop circuits. The resultant counts are then used to calibrate the TEC circuits. Once these are calibrated the value of the frequency of the input can be calculated to a much greater resolution.

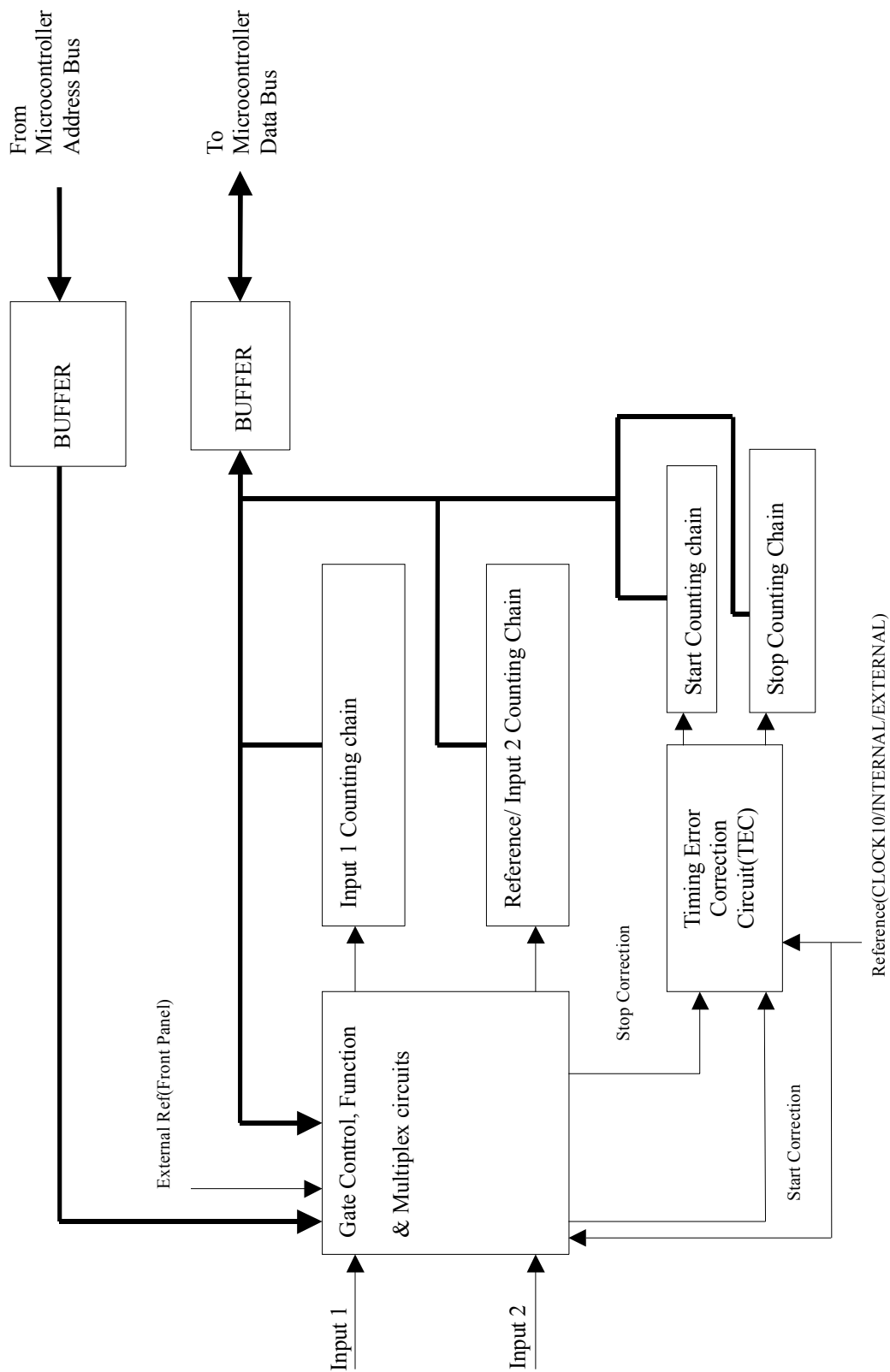

Figure 1-7, Measurement Block

This page was left intentionally blank.

Chapter 2

INSTALLATION INSTRUCTIONS

Unpacking and Inspection

1. Before unpacking the switching module, check the exterior of the shipping carton for any signs of damage. All irregularities should be noted on the shipping bill.
2. Remove the instrument from its carton, preserving the factory packaging as much as possible.
3. Inspect the module for any defect or damage. Immediately notify the carrier if any damage is apparent.
4. Have a qualified person check the instrument for safety before use.

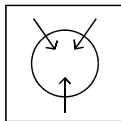

NOTE:

Proper ESD handling procedures must always be used when packing, unpacking, or installing any function card. Failure to do so may cause damage to the unit.

Reshipment Instructions

1. Use the original packing material when returning the function card to Racal Instruments for calibration or servicing. The original shipping carton and the instrument's plastic foam will provide the necessary support for safe reshipment.
2. If the original packing material is unavailable, wrap the module in plastic sheeting and use plastic spray foam to surround and protect the instrument.
3. Reship in either the original or a new shipping carton.

Installation

If The Function Card is ordered on its own, it must be installed in a 2460 Series VXIbus module before it can be used.

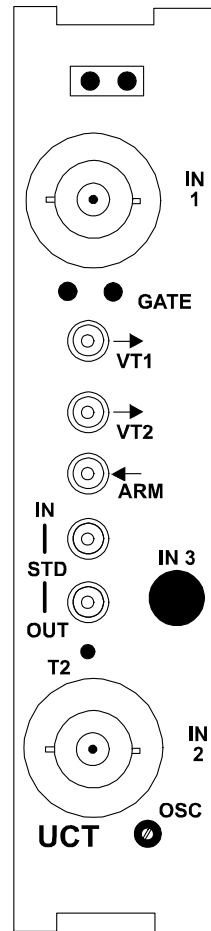

Figure 2-1, The Universal Counter Timer

To do this, remove the 2460 VXIbus module from the chassis/mainframe and then remove the right side cover from the module. Remove the four screws near the front, one screw in the center about 4 inches from the rear, and one screw in the center rear of the cover, between the connectors. Additionally, there are eight screws (four on either side) on the sides of the cover. This will give access to the inside of the module.

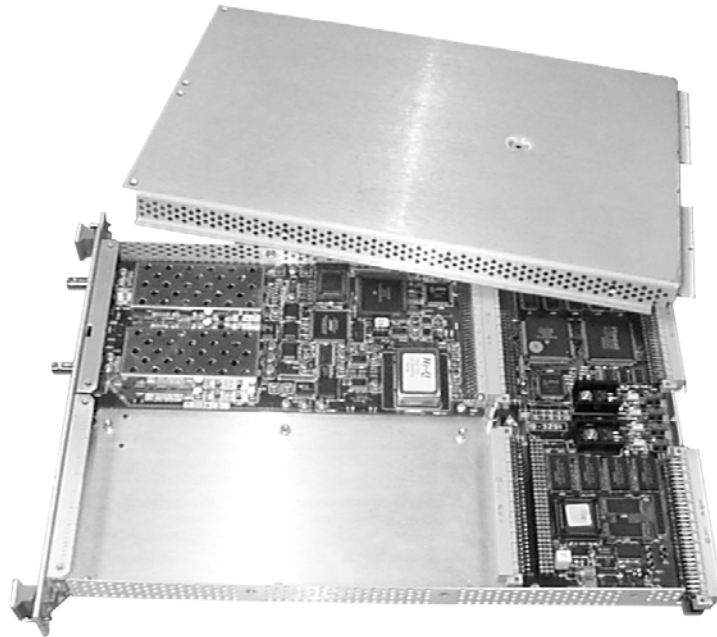

Figure 2-2, Removing the Screws from the Module

Additionally, the front panel must be removed. There are eight screws that must be removed. Four for each of the small front panels.

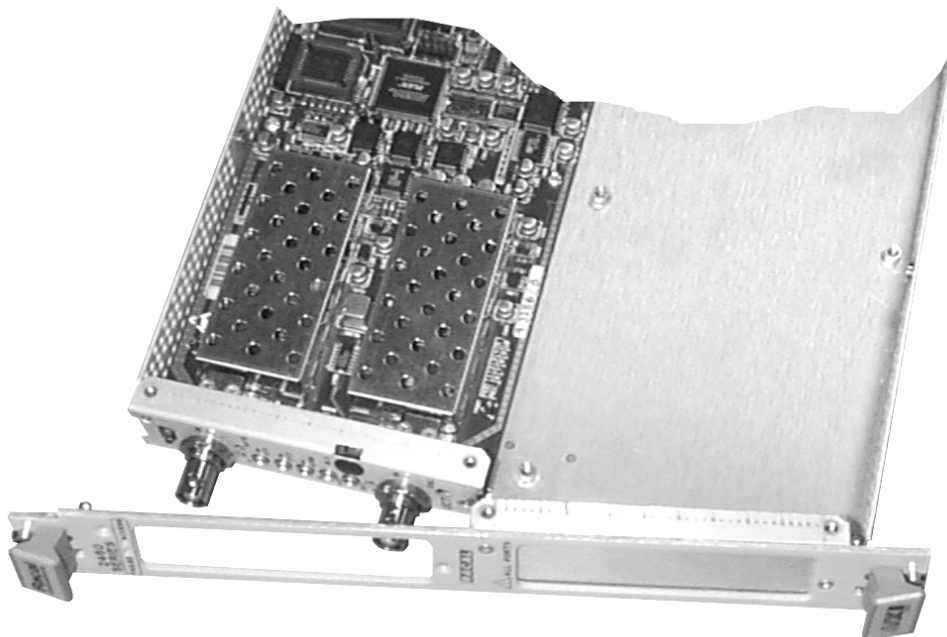

Figure 2-3, Removing the Front Panel

Once the front panel is removed, insert the Function Card (Universal Counter Timer) into the 2460 taking care to mate this connector on the function card with that inside the 2460. Note if only one function card is to be installed, it must be placed in position/slot 1(see Figure 2-2). Secure it by screwing it down. There are four screws to install.

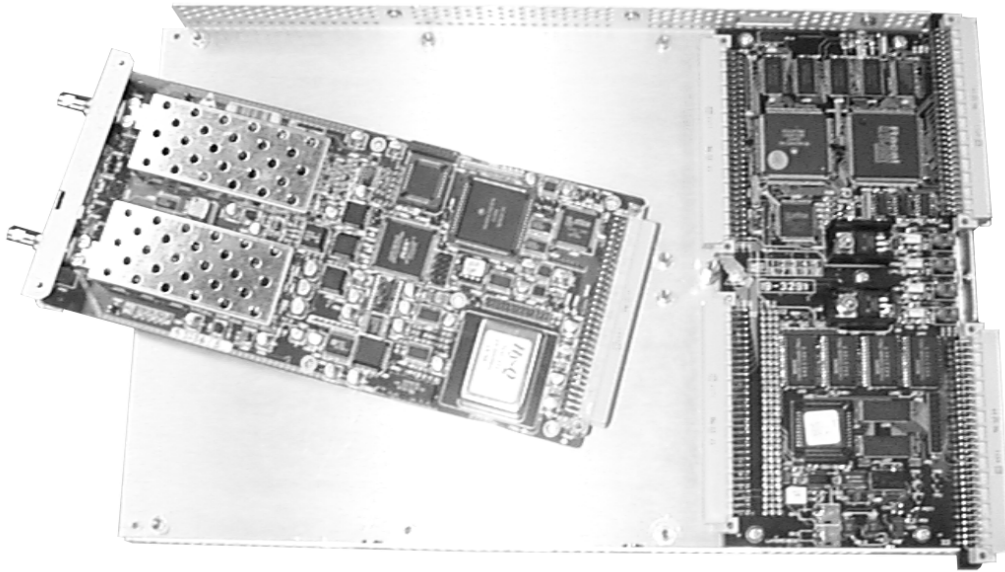

Figure 2-4, The 2461 Type C

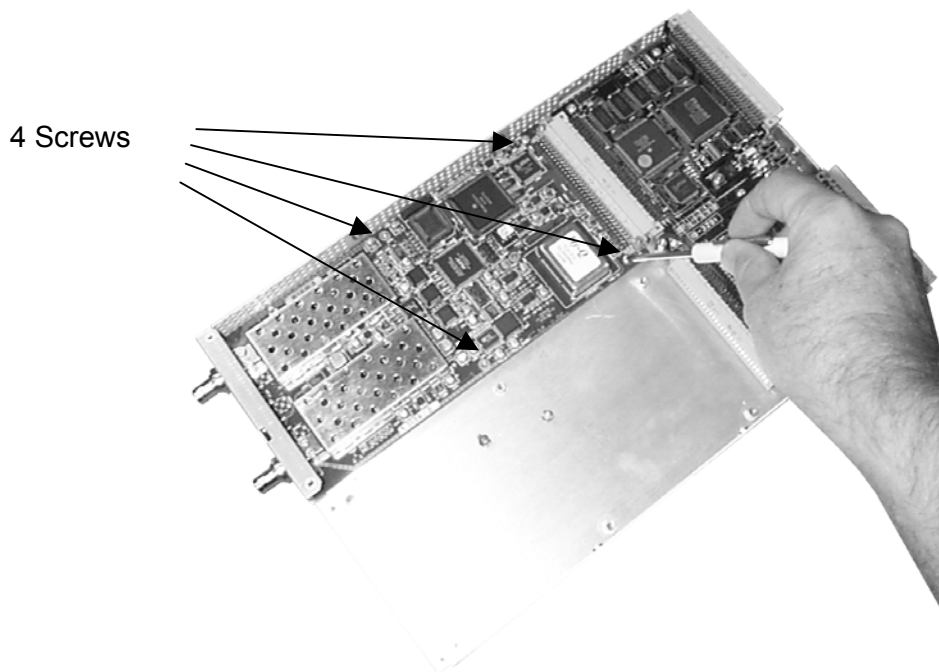

Figure 2-5, Tightening the Four Screws.

After installing the function card, put on the front panel. This is done in the reverse order from taking it apart. Install it by replacing the eight screws for the front panel. Then replace the cover using the four screws for the front, one for the middle, and one for the rear.

Label Requirements

Alterations to the label- due to modifications performed by the user (retrofitting new function cards or altering the configuration, for example) – will be the responsibility of the user. To update the configuration label on the 2461 the users should mark any changes in performance due to upgrades, e.g. peak and dynamic currents, etc. on the label found on the side panel on the module.

This information is required if a unit is returned to an approved service center for repair. Should a module be returned to a service center for function cards to be installed, the service center will update the label.

If the function cards are factory installed by Racal Instruments, Inc. A specific label will be produced for the particular configuration.



Logical Address		RACAL INSTRUMENTS INC.					
0	<input type="text"/>	#4 Goodyear Street, Irvine, CA 92618					
1	<input type="text"/>	(949) 859-8999 or (800) RACAL-ATE (Outside California)					
MSB	LSB	MODEL: 2461-CD (2461RT LOAD MODULE)		Interrupt Level: _____			
		P/N: 2461-CD		Logical Address: _____			
		S/N: 04010053					
GENERAL VXibus INFORMATION							
VXibus REV:		1.4					
DEVICE TYPE:		MESSAGE BASED SERVANT					
ADDRESSABLE MEMORY:		D16/A32/D16					
POWER/COOLING REQUIREMENTS							
Voltage:	+5	+12	+24	-2	- 5.2	- 12	-24 +5STDBY
Peak mA:	1280	0	165	20	380	0	140 0
Dyn. mA:	50	0	10	10	60	0	10 0
Power:	15.74W. max						
Airflow:	41S ⁻¹ Liters/Sec at 0.14mm H2O						
Temperature:	50C Maximum Ambient						
		INSTRUMENT OPTIONS					
		(1):		(2):			

Figure 2-6, The Racal Instruments Label

NOTE:

Refer to Chapter 6 for the Performance Verification Procedure.

Chapter 3

THEORY OF OPERATION

Functional Systems

The 2461 Type C card comprises 3 functional systems as follows:

1. The Input Channels 1 & 2 System
2. The Input Channel 3 System
3. The Measurement System
4. The Microprocessor System

Input Channels 1 & 2 System

The Input Channels 1 and 2 System comprises two channels that process the signals applied to Input 1 and Input 2 respectively to produce differential pairs of signals that are fed to the measurement system. A block diagram is given in Figure 3-1.

Each channel includes relay-controlled circuits which allow selection of $50\Omega/1M\Omega$ input impedance, AC/DC coupling, X1/X10 input attenuation and 50kHz filter. A further relay allows the user to choose between SEPARATE and COMMON modes of operation. In SEPARATE mode the signal on Input 1 is fed to the channel 1 active circuits and the signal on Input 2 is fed to the channel 2 active circuits. In COMMON mode the signal on Input 1 is fed in parallel to both the channel 1 and channel 2 active circuits. In this mode signals on Input 2 are disconnected from the channel 2 active circuits, but remain connected to the $50\Omega/1M\Omega$, AC/DC and X1/X10 selection circuits.

Each channel features separate high frequency and low frequency paths whose outputs in normal operation are recombined with a crossover frequency of 5kHz nom. With FILTER selected, the high frequency path is disabled, and the bandwidth of the low frequency path set to 50kHz nom. The buffered signals from each channel drive separate ground-referenced Schmitt trigger output stages.

Trigger levels for the two channels are derived independently in the DAC (Digital to Analog Converter) System and applied independently to each input channel. These trigger levels are also made available at the front panel (buffered by 10k Ω nom. resistance). The DAC System incorporates separate trimming DACs which are used to calibrate the trigger DACs. The DAC System also incorporates DACs that allow channel 1 and channel 2 offset voltage correction, and DACs that allow control of channel 1 and channel 2 sensitivity. Control of all DACs is via the microprocessor system. DAC calibration values are stored in non-volatile memory.

Control signals for the relays are supplied by the microprocessor system.

Input Channel 3 System

The Input Channel 3 System processes the signal applied to Input 3 (if Option 41 is installed) and feeds it to the measurement system. A block diagram of Channel 3 is shown below.

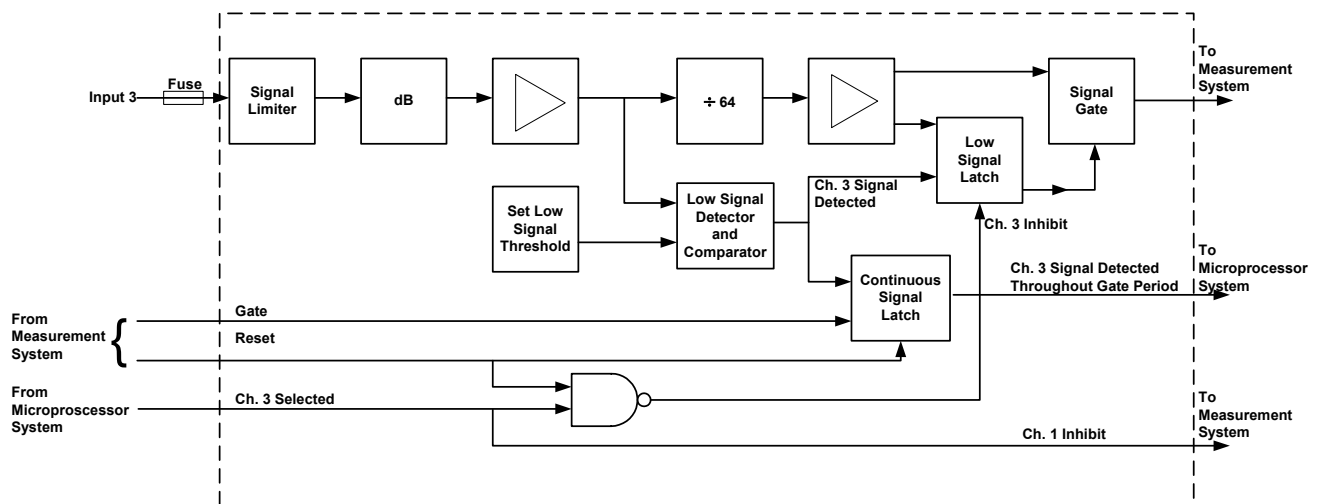

Channel 3's input is protected by a fuse mounted in the input connector and by a signal-limiting circuit. Next is an automatic level control circuit which reduces the range of the signal level applied to the amplifier.

After amplification, the signal is pre-scaled by 64 before being passed via a buffer and a signal gate to the measurement system.

The amplitude of the signal at the amplifier output is monitored by a detector and a comparator. The comparator output controls the low signal latch. If the detector output is below the

threshold, the latch is set and the channel output is inhibited by the signal gate. When the detector output goes above the threshold, the low signal latch is armed and opens the signal gate on the next signal edge from the pre-scaler. This enables the instrument to make measurements on signal bursts.

The detector output is also applied to the continuous signal latch. This latch is reset at the beginning of each gate period and is set if the detector output falls below the threshold level. The microprocessor samples the latch output throughout the gate period. If the measured signal falls below the threshold level during this period, the measured result is set to zero.

When Channel 3 is not selected, the low signal latch is held in reset by a control signal from the microprocessor and the output to the measurement block is inhibited. The same control signal is used to enable Channel 1 so that the two channels cannot be enabled at the same time.

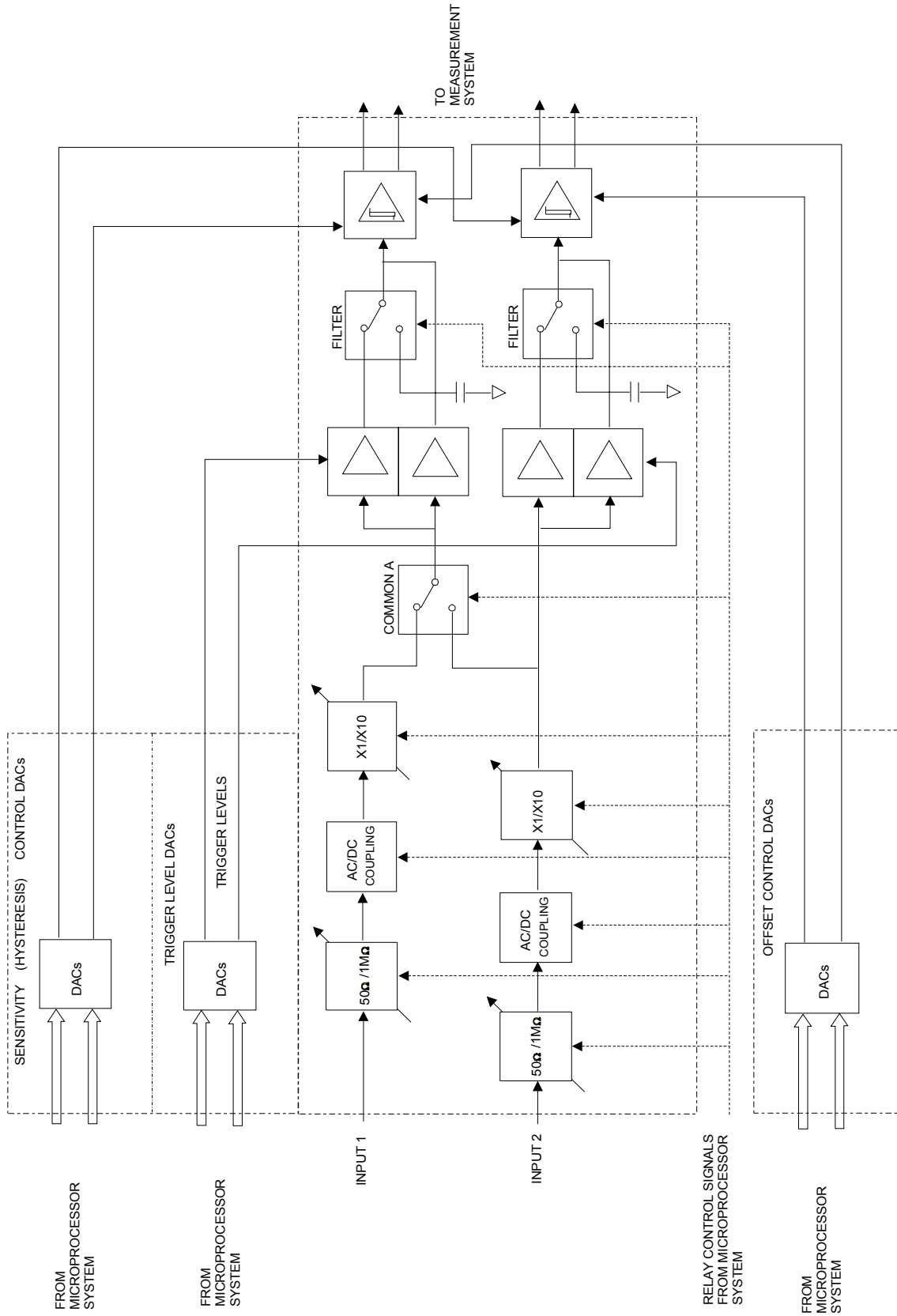

Figure 3-1, Inputs 1 & 2

Measurement System

The measurement block is mainly implemented within an Altera Erasable Programmable logic Device (EPLD). The Timing Error Correction (TEC) circuit is external to this.

Referring to the block diagram (Figure 3-2), the measurement block consists of a high speed front end which takes in Input 1 & 2 after conditioning by the input amplifiers. This front end has connections to microprocessor data *bus* to allow the micro to configure the measurement block for the type of measurement to be taken. The micro also drives the measurement process by controlling the arming of the start and stop of the measurement.

After a measurement has taken place, the micro reads the values in the various counting chains via the data *bus*. The measurement block uses interrupts to communicate the various events that occur in the measurement block.

The measurement technique employed is known as the recipromatic measurement technique. In this technique the signal and reference are counted simultaneously. This has the advantage that for signals of less than 10 MHz, accuracy is maintained because of the large number of counts in the reference counter. In addition the opening and closing of the gate is synchronized to the signal which, together with the Timing Error Correction (TEC) circuit allows higher resolution equivalent to a 1GHz reference.

In this system, the first edge of the incoming frequency to be measured (after the μ P has armed the start of measurement), opens the gate and simultaneously allows the signal through to the input 1 counting chain and the frequency reference through to the reference counting chain. Both signals are now counted for the duration of the gate time. The μ P determines the length of the gate time using its on-board timer which is set by the resolution needed by the operator.

At the end of the gate time, the μ P arms the end of measurement and the next edge of the input signal closes the gate and the two counting chains stop counting.

In the above description, there are two points at which resolution is limited by the 10 MHz reference, the opening of the gate and the closing. To overcome this limitation, the time between the signal opening the gate and the next edge of the reference, is detected by logic gates in the front end. Additionally, a pulse whose width is proportional to this time is generated. This pulse is now used to charge a capacitor from a constant current source so the charge on the capacitor is proportional the time error. The charge is then discharged at a much slower rate and while this is going on the reference is

counted in the start counting chain. When the capacitor is discharged then the count in the start counting chain represents the error between the opening of the gate and the next counting edge of the reference (See Figure 3-2).

This process is repeated at the closure of the gate by a separate TEC and counting circuit (the stop counting chain).

After the measurement results have been read out of all counters, calibrated pulses derived from the reference are fed to the TEC circuits. This is done for two pulse widths for both start and stop circuits. The resultant counts are then used to calibrate the TEC circuits. Once these are calibrated the value of the frequency of the input can be calculated to a much greater resolution.

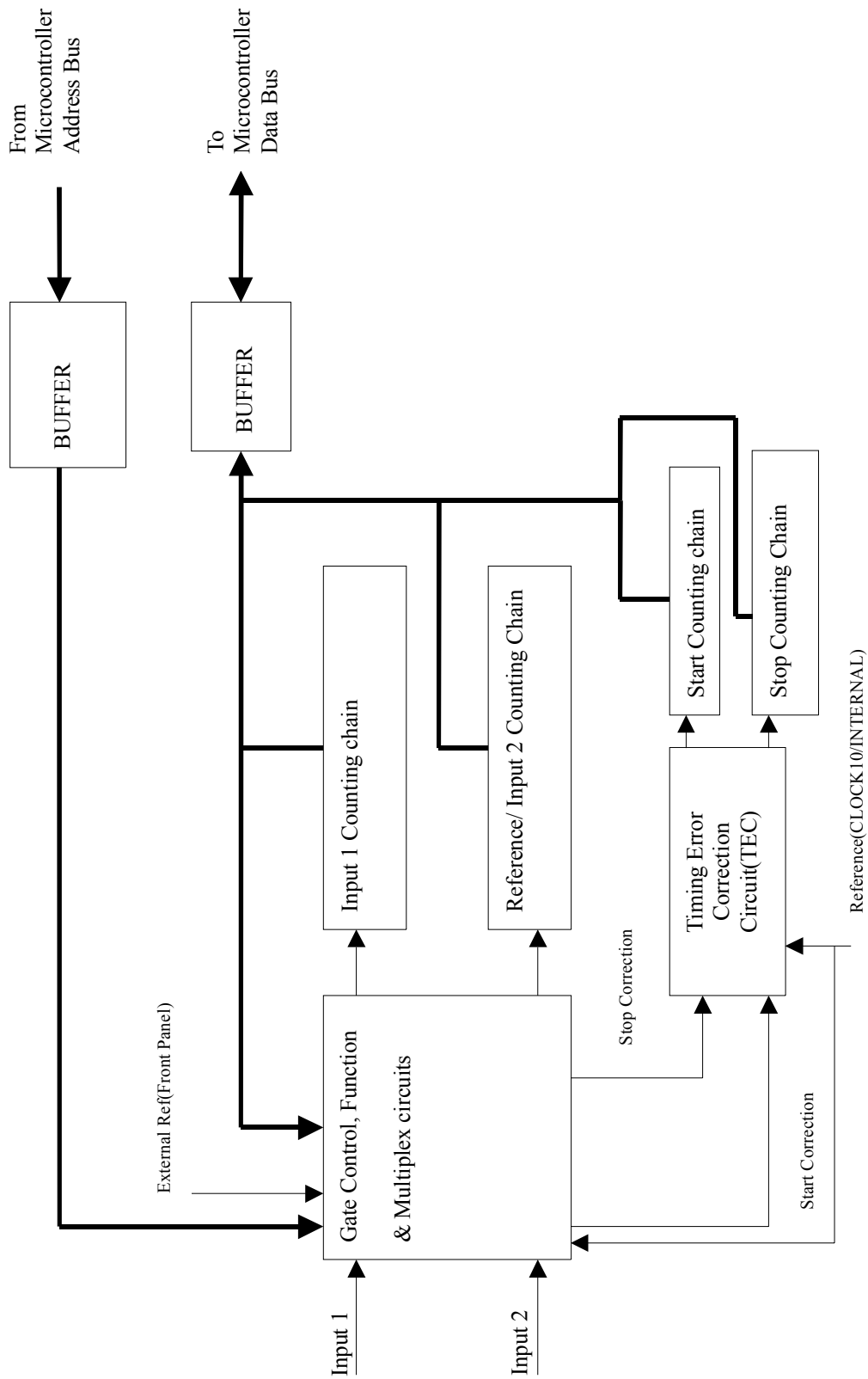

Figure 3-2, Measurement Block

Microprocessor System

Referring to the block diagram, the processor system is based on a microcontroller design which drives both the input conditioning relays, calibration DAC and trigger level DACs.

In addition the processor drives the measurement system and performs the necessary calculations to produce a result which is then passed to the VXI interface card processor for transmission over to the VXI *bus* if necessary.

The microcontroller used has both a number of static I/O ports in addition to an externally available address and data base. This mixture of I/O allows memory mapped I/O for fast peripherals such as the measurement system while the static I/O ports are used control of relays, standards, etc.

Firmware is stored in conventional EPROM while non-volatile constants are stored in a serial EEPROM. Address decode and further I/O is performed in the EPLD along with the measurement system

After power up the microcontroller reads calibration data from the serial EEPROM and the 8X8 bit DAC are initialized. The measurement system, trigger level DACs and input conditioner relays, are set to their default values. The system will now wait for an initiate command, sent via the VXI interface processor, before a measurement sequence will commence. Alternately, the operator may command alternative measurement functions or input conditions via the VXI interface processor.

Any type of command from the VXI *bus* will be passed from the VXI processor to the microcontroller via the interface logic. The content of the message passed will cause the microcontroller to change various conditions, measurement functions, or trigger one or more measurement cycles.

Each successful measurement cycle will result in a measurement result which is transferred to the VXI microcontroller as soon as it is calculated and before the next measurement cycle commences.

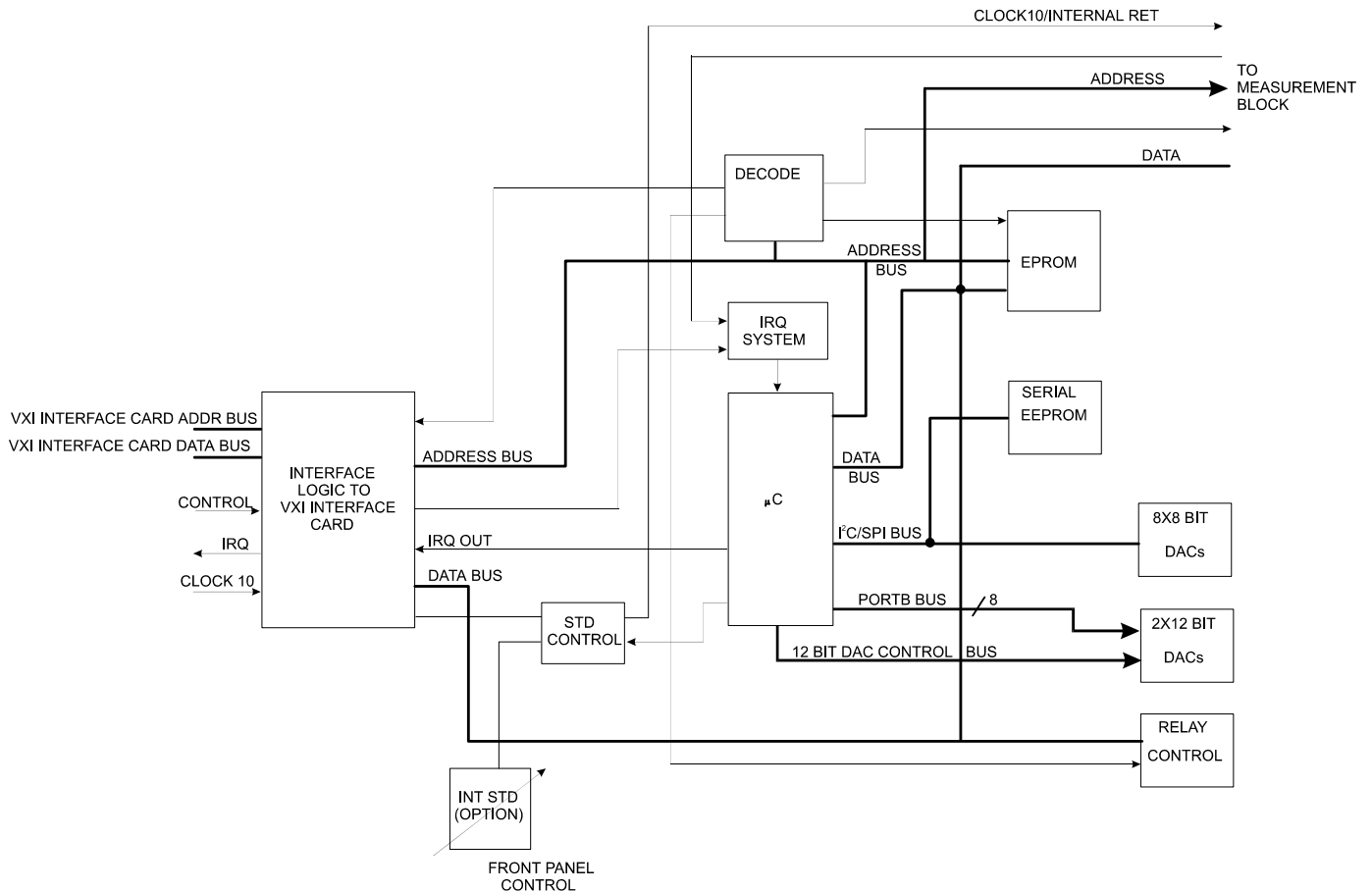

Figure 3-3, Block diagram of processor system

Details of the Counter

The 2461 Type C is a microprocessor controlled instrument offering high-resolution measurement capabilities. The instrument is designed to be used under the direction of the Slot 0 System Resource Manager of a VXIbus compatible mainframe. The instrument conforms to VXIbus System Specification Revision 1.4.

The standard unit uses the VXI 'CLOCK10' as its reference. However, the user can choose between two optional internal reference standards, a TCXO and an OCXO. The unit can also be configured to accept an external 10 MHz frequency reference connected to the front panel.

The 2461 Type C is designed to be controlled via the VXIbus. No local control of the counter is possible. The command set for the 2461 Type C is defined in Chapter 4 of this manual.

Measurement Functions

The following measurement functions are available in the 2461 Type C:

Frequency Input 1

Measures the frequency of the signal applied to Input 1.

Frequency Input 2

Measures the frequency of the signal applied to Input 2.

Period Input 1

Measures the period of the signal applied to Input 1.

Period Input 2

Measures the period of the signal applied to Input 2.

Time Interval Input 1 to Input 2

Measures the time interval between an event at Input 1 (START) and an event at Input 2 (STOP).

It is possible to delay the arming of the STOP circuit; this feature may prevent premature triggering of the STOP circuit due to external noise (e.g. contact bounce from a switch generating the START event).

Time Interval Input 2 to Input 1

Measures the time interval between an event at Input 2 (START) and an event at Input 1 (STOP).

It is possible to delay the arming of the STOP circuit; this feature may prevent premature triggering of the STOP circuit due to external noise (e.g. contact bounce from a switch generating the START event).

Totalize Input 1 by Input 2

Displays the sum total of events occurring at Input 1 during the interval between START and STOP events at Input 2. The action is as follows:

INPUT 2 Slope	START	STOP
POSITIVE	↑	↓
NEGATIVE	↓	↑

It is possible to delay the arming of the STOP circuit; this feature may prevent premature triggering of the STOP circuit due to external noise (e.g. contact bounce from a switch generating the START event).

Totalize Input 2 by Input 1

Displays the sum total of events occurring at Input 2 during the interval between START and STOP events at Input 1. The action is as follows:

INPUT 1 Slope	START	STOP
POSITIVE	↑	↑
NEGATIVE	↓	↓

It is possible to delay the arming of the STOP circuit; this feature may prevent premature triggering of the STOP circuit due to external noise (e.g. contact bounce from a switch generating the START event).

Manual Totalize Input 1

Displays the sum total of events occurring at Input 1 between START and STOP events provided either by means of SCPI commands or a button on the soft front panel of the *VXIplug&play* install disk (Racal Instruments part number 60-0087).

The summation of events is cumulative over successive periods until the count is cleared by means of either a SCPI command or a button on the soft front panel of the *VXIplug&play* install disk.

Manual Totalize Input 2

Displays the sum total of events occurring at Input 2 between START and STOP events provided either by means of SCPI commands or a button on the soft front panel of the *VXIplug&play* install disk (Racal Instruments part number 60-0087).

The summation of events is cumulative over successive periods until the count is cleared by means of either a SCPI command or a button on the soft front panel of the *VXIplug&play* install disk.

Ratio Input 1/Input 2

Measures the ratio of the frequencies applied to Input 1 and 2.

Ratio Input 3/Input 2

Measures the ratio of the frequencies applied to Input 3 and 2.

Check

Checks the counting circuits for basic functionality. Counting circuits that are working correctly will return a

reading of 10.00000000E6 Hz.

Phase of Input 1 relative to Input 2

Measures the phase difference between the waveforms applied to Inputs 1 and 2. The value displayed is the phase lead of Input 1 in degrees.

Note: A continuous signal is required during a phase measurement.

Phase of Input 2 relative to Input 1

Measures the phase difference between the waveforms applied to Inputs 2 and 1. The value displayed is the phase lead of Input 2 in degrees.

Note: A continuous signal is required during a phase measurement.

Risetime Input 1

Measures the 10% to 90% risetime of the waveform at Input 1.

Falltime Input 1

Measures the 90% to 10% falltime of the waveform at Input 1.

Positive pulse width Input 1

Measures the width of positive going pulses at Input 1 (i.e. ↑ edge to ↓ edge).

Negative pulse width Input 1

Measures the width of negative going pulses at Input 1 (i.e. ↓ edge to ↑ edge).

Volts middle Input 1

Measures the middle (mean) voltage of the waveform at Input 1.

Volts middle Input 2

Measures the middle (mean) voltage of the waveform at Input 2.

Volts maximum Input 1

Measures the maximum (peak) voltage of the waveform at Input 1.

Volts maximum Input 2

Measures the maximum (plus peak) voltage of the waveform at Input 2.

Volts minimum Input 1

Measures the minimum (minus peak) voltage of the waveform at Input 1.

Volts minimum Input 2

Measures the minimum (minus peak) voltage of the waveform at Input 2.

MATH FACILITY

The Math Facility offers the following algorithm:

$$\text{Reading} = \frac{\text{Result-Offset}}{\text{Scale}}$$

Where: Offset=0 and Scale=1 by default

AVERAGING

This facility returns the average of 100 measurements for the following functions:

- Frequency Input 1
- Frequency Input 2
- Frequency Input 3
- Period Input 1
- Period Input 2
- Ratio Input 1/Input 2
- Ratio Input 3/Input 2
- Time Interval Input 1 to Input 2
- Time Interval Input 2 to Input 1

AUTOMATIC/MANUAL TRIGGERING

The trigger level can be set automatically or manually.

Automatic

In automatic mode, the system measures the positive and negative peaks of the signal and sets the trigger voltage to the mid-point.

Certain restrictions regarding minimum amplitude and frequency apply in this mode. A choice of minimum frequency limit is available. However, the system is able to work with DC voltages (i.e. voltages with no or very small AC content. For such DC inputs, the trigger level and the displayed peak voltages will be set to the perceived average value of the input (i.e. the perceived DC level).

During auto-triggering, the system will automatically select

the X10 attenuator if the input level is too high for the X1 attenuator setting.

Single shot autotrigger is available.

Manual

In manual trigger mode, the user can manually set the required trigger voltage.

Selecting manual trigger after automatic triggering retains the auto-set trigger level.

TRIGGER SLOPE SELECTION

Used to select which edge of the input signal, \uparrow or \downarrow , is used for triggering the START of the measurement and which edge is used for triggering the STOP.

Signal Inputs

Inputs 1 and 2 are connected to essentially independent channels that permit the selection of:

- AC or DC coupling.
- 1M Ω or 50 Ω nom. input impedance.
- X1 or X10 input attenuation.
- 50kHz nom. input filter.
- Positive or negative slope triggering.
- Manual or automatic setting of trigger levels.

In addition to independent (SEPARATE mode) operation, it is possible to connect the signal at input 1 in parallel to both channel 1 and channel 2 active circuits (COMMON mode). In this mode signals on Input 2 are disconnected from the channel 2 active circuits, but remain connected to the 50 Ω /1M Ω , AC/DC and X1/X10 selection circuits.

Input 3 (with option 41) is AC coupled with a 50 Ω input impedance. These settings are not programmable. A field-replaceable connector-mounted fuse is in series with Input 3. Option 69 (package of replacement fuses) may be ordered as P/N R-11-1718.

Additional

ARMING

Capabilities

Arming of the START and STOP circuits can be either internally or externally derived. External arming is possible on all functions except phase. The following arming modes are available:

Mode	Start	Stop
1	INT ARM	INT ARM
2	EXT ARM ↑	INT ARM
3	EXT ARM ↓	INT ARM
4	INT ARM	EXT ARM ↑
5	INT ARM	EXT ARM ↓
6	EXT ARM ↑	EXT ARM ↑
7	EXT ARM ↑	EXT ARM ↓
8	EXT ARM ↓	EXT ARM ↑
9	EXT ARM ↓	EXT ARM ↓

The EXT ARM input can be from any of the VXI TTLO-7 lines, or from the front panel ARM input.

For modes that use INT ARM, the STOP arming hold-off time is adjustable for time interval measurements.

Correct use of the arming facilities can be used, for example, to prevent premature triggering of the START and/or STOP circuits due to external noise (e.g. contact bounce).

EXTERNAL FREQUENCY REFERENCE INPUT

The 2461 Type C can make measurements using as its frequency reference an external signal connected to the front panel port marked STD IN.

INTERNAL FREQUENCY REFERENCE OUTPUT

The frequency reference in use is available at the front panel port marked STD OUT.

FREQUENCY STANDARD SELECTION

The user can select the reference from any of three sources to

make the measurement. The choices are:

Clock 10	(VXI source)
External	(via front panel STD IN port)
Internal	(from the optional internally fitted reference oscillator)

GATE OUTPUT

The measurement gate pulse can be made available (user selectable) at any one of the VXI trigger lines TTL0-7.

INTERNAL FREQUENCY REFERENCE ADJUSTER

The optional internal frequency reference oscillator can be adjusted by means of the front panel control marked OSC.

Chapter 4

PROGRAMMING THE TYPE C FUNCTION CARD

Introduction

This Chapter provides information for programming the 2461 Type C function card via the *VXIbus* interface when the 2461 is mounted in a 2460 *VXIbus* Module. The *VXIbus* interface permits control of all the 2461 Type C functions.

The Chapter includes:

Specific Commands

Specific Error Messages

Examples of Use

Default Conditions

The 2461 TYPE C Default Conditions form the default configuration that the 2461 TYPE C will adopt when the 2460 VXI Module is powered up.

General default conditions

COMMAND	*RST OR SYSTEM:PRESET
IEEE 488.2 COMMON COMMANDS	
ALL COMMANDS	UNAFFECTED
STATUS SUBSYSTEM	
ALL COMMANDS	UNAFFECTED
INSTRUMENT SUBSYSTEM	
INST:SEL	COUNTER1

Counter default conditions

COMMAND	*RST OR SYSTEM:PRESET
CALCULATE SUBSYSTEM	
CALCulate :MATH :STATe	OFF
INPUT SUBSYSTEM	
INPut[1 2] :ATTenuation :COUPling :IMPedance :ROUte :FILTer [:LPASs] [:STATe] :COMParator :LEVel [:ABSolute] :HYSteresis :RELative :SLOPe :SETup :AUTO :FREQuency	1 AC 1M Ohm SEP OFF 0 MIN POS OFF 1000

COMMAND	*RST OR SYSTEM:PRESET
MEASUREMENT INSTRUCTION	
CONFigure	"FREQ"(channel 1 in SCALar mode)
OUTPUT SUBSYSTEM	
OUTPut :TTLTrg<N> [:STATe]	OFF
SENSE SUBSYSTEM	
[SENSe[1 2 3]] :FUNctIon :APERture :AVERage [:STATe] :TINTerval :DELay :TIME [:STATe] :TOTalize :GATE [:STATe] :POLarity :INTermediate :MANual :RESolution	FREQ1 (SCALar) 100ms OFF MIN OFF OFF NORM OFF OFF 8
SOURCE SUBSYSTEM	
SOURce :ROSCillator [:SOURce]	CLOCK10
SYSTEM SUBSYSTEM	
SYSTem:TIMeout	
TEST SUBSYSTEM	
TEST[1 2] :RELay [:STATe] :TEC :SHORT [:STATe] :LONG [:STATe] :DAC [:STATe]	OFF OFF OFF OFF

COMMAND		*RST OR SYSTEM:PRESET
TRIGGER SUBSYSTEM		
INITiate	:(CONTInuous [IMMEDIATE])	OFF
ABORt		
ARMing	:([SEQUence1] START):[LAYer]	POS
	:SLOPe	IMM
	:SOURce	
	:(SEQUence2 STOP)	POS
	:SLOPe	IMM
	:SOURce	

Functional Check

INTRODUCTION

The following procedure verifies that the 2461 TYPE C can accept, process, and transmit device- dependent messages over the *VXIbus*.

VXIBUS Communication Check

Perform the following procedure:

- (1) Power-on the VXI Chassis/Mainframe containing the 2461
- (2) Perform a test as shown below:

Action
Send the IEEE-488.2 command "*TST?"

- (3) Read the data in the output buffer.

Action	Self Test Data
Read Data	"0" = Pass NON Zero value indicates a failure

List of SCPI Commands

CALCulate Command Summary

COMMAND	DESCRIPTION
CALCulate :MATH:EXPRession :STATe	Specify which expression is to be used. Enable or Disable math processing.

MEASurement command summary

COMMAND	DESCRIPTION
CONFigure[1 2 3] :([SCALar] ARRay) :VOLTage :MINimum :MAXimum :MIDDLE :FREQuency :FREQuency:RATio :FALL:TIME :FTIME :RISE:TIME :RTIME :PERiod :PWIDth :NWIDth :TINTerval :TOTalize :PHASe :CHECK	Configures the instrument for: Trigger level negative peak measurement Trigger level positive peak measurement Trigger level voltage measurement Frequency measurement Ratio of frequencies measurement Fall time measurement Alias for fall time measurement Rise time measurement Alias for rise time measurement Period measurement Positive pulse width measurement Negative pulse width measurement Time interval measurement Totalize measurement Phase difference between waveforms Functional tests

COMMAND	DESCRIPTION
FETCh [:VOLTage]? [:MINimum]? [:MAXimum]? [:MIDDLE]? [:FREQuency]? [:FREQuency:RATio]? [:FALL:TIME]? [:FTIME]? [:RISE:TIME]? [:RTIME]? [:PERiod]? [:PWIDth]? [:NWIDth]? [:TINTerval]? [:TOTAlize]? [:PHASe]? [:CHECK]?	Retrieves the following measurements: Trigger level voltage Minimum trigger level voltage Maximum trigger level voltage Middle trigger level voltage Frequency Ratio of frequencies Fall time Alias for fall time Rise time Alias for rise time Period Positive pulse width Negative pulse width Time interval Totalize Phase difference Functional tests

COMMAND	DESCRIPTION
MEASure[1 2 3] :([SCALar] ARRay) :VOLTage :MINimum :MAXimum :MIDDLE :FREQuency :FREQuency:RATio :FTIME :FALL:TIME :RTIME :RISE:TIME :PERiod :PWIDth :NWIDth :TINTerval :TOTAlize :PHASe :CHECK	Performs: Trigger level negative peak measurement Trigger level positive peak measurement Trigger level voltage measurement Frequency measurement Ratio of frequencies measurement Fall time measurement Alias for fall time measurement Rise time measurement Alias for rise time measurement Period measurement Positive pulse width measurement Negative pulse width measurement Time interval measurement Totalize measurement Phase difference between waveforms measurement Functional tests

COMMAND	DESCRIPTION
READ?	Initiates a measurement and returns the value.

INPut command summary

COMMAND	DESCRIPTION
INPut[1 2]	
:ATTenuation	Selects x1 or X10 attenuation.
:COUPling	Selects AC or DC coupling.
:IMPedance	Selects 50Ω or 1MΩ input impedance.
:ROUte	Separates or commons input channel 1 and 2.
:FILTer	
[:LPASs]	
[:STATe]	Enables or disables low-pass filter.
:COMParator	
:LEVel	
:RELative	Selects relative trigger voltage level.
[:ABSolute]	Selects absolute trigger voltage level.
:HYSTeresis	
:RELative	Enables or disables hysteresis.
:SLOPe	
:SETup	Selects comparator slope.
:AUTO	
:FREQuency	Enables, continuously or singly, or disables auto trigger.
	Selects the minimum frequency of the auto trigger algorithm

OUTPut command summary

COMMAND	DESCRIPTION
OUTPut	
:TTLTrg<n>	
[:STATe]	Enables or disables the selected trigger line.

SENSe command summary

COMMAND	DESCRIPTION
[SENSe[1 2 3]] :FUNcTion	Selects measurement function: "PERiod", "FREQUency ", "FREQUency:RATio", "TINTerval", "RTIME", "RISE:TIME", "FTIME", "FALL:TIME", "PWIDth", "NWIDth", "PHASe", "CHECK", "TOTAlize", "VOLTage:MAXimum", "VOLTage:MINium", "VOLTage:MIDDLE"
[SENSe] [:PERiod] :APERTure [:FREQUency] :APERTure [:FREQUency:RATio] :APERTure [:TINTerval] :APERTure [:RTIME] :APERTure [:RISE:TIME] :APERTure [:FTIME] :APERTure [:FALL:TIME] :APERTure [:PWIDth] :APERTure [:NWIDth] :APERTure [:PHASe] :APERTure [:TOTAlize] :APERTure [:CHECK] :APERTure	Selects the measurement aperture (gate time). The function parameter is optional because the aperture value applies to all functions.
:AVERAGE [:STATe]	Enables or disables average.
:TINTerval :DELay :TIME [:STATe]	Selects time delay. Enables or disables time interval.
:TOTAlize :GATe [:STATe] :POLarity :INTermediate :MANual	Selects TOTAlize 1 by 2, 2 by 1 or Manual Totalize. Selects slope of channel. Enables on-the-fly Totalize measurements Starts and Stops Manual Totalize
:RESolution	Specifies number of digits of resolution.

SOURce command summary

COMMAND	DESCRIPTION
SOURce :ROSCillator [:SOURce]	Selects the source of the 2461 TYPE C 10 MHz reference oscillator.

TEST command summary

COMMAND	DESCRIPTION
TEST[1 2] :RELay [:STATe] :TEC :SHORT [:STATe] :LONG [:STATe] :DAC [:STATe]	Test 2461 TYPE C relays. Test short period TEC. Test long period TEC. Test ramp trigger DAC's

TRIGger command summary

COMMAND	DESCRIPTION
INITiate :(CONTInuous [IMMediate])	Enter in the INITiate state.
ABORt	Aborts any operation in progress.
ARMing :([SEQuence1] START)[:LAYer] :SLOPe :SOURce :(SEQuence2 STOP) [:LAYer] :SLOPe :SOURce	Slope of the arming signal for start. Source of the arming signal for start. Slope of the arming signal for stop. Source of the arming signal for stop.

2461 TYPE C Commands

CALCULATE Subsystem

The CALCulate subsystem is used to perform post-acquisition data processing.

In the following sections of the manual references are made to channels 1 and 2. These refer to the 2461 TYPE C Input 1 and Input 2.

CALCulate command summary

COMMAND	DESCRIPTION
CALCULATE :MATH:EXPRession :STATe	Specify which expression is to be used. Enable or Disable math processing.

CALCulate:MATH:EXPRession

<(VALUE1,VALUE2)|(MEAS,VALUE2)|(VALUE1,MEAS)>

DESCRIPTION:

This command specifies which expression is used by the CALCulate block. The parameters are the offset and the scale factors respectively.

MEASure refers to the previous measurement. <value1> and <value2> are the offset and scale factors.

If MEASure is specified for the offset value, then the previous measurement is used as the offset. If MEASure is specified for the scale factor, then the previous measurement is used as the scale factor. Note that at power-up, the default value of the previous measurement is zero.

The permitted number of significant digits for <value1> and <value2> is 9. The display range is from 9.99999999E+9 to -9.99999999E±9.

The following algorithm will be invoked:

$$\frac{\text{result} - \text{offset}}{\text{scale}}$$

PARAMETER:

The allowed range for <value1> and <value2> is:

1E-9 < value < 1E10

0

-1E10 < value < -1E-9

INITIALIZATION: *RST value1 = 0 (offset)

value2 = 1 (scale)

EXAMPLE:

"CALCulate:MATH:EXPRession 1000,MEASure"

Specifies an offset of 1000 and instructs the 2461 TYPE C to use the previous measurement as a scale factor.

INTERROGATIVE FORM:

CALCulate:MATH:EXPRession? ==> <offset value, scale value>

Returns the offset and scale values currently selected.

CALCulate:STATe <OFF | ON>

DESCRIPTION:

This command enables or disables the math processing that is specified by the CALCulate:MATH:EXPRession command.

INITIALIZATION:

*RST OFF

EXAMPLE:

"CALCulate:STATe ON"

Enables the math post-processing.

INTERROGATIVE FORM:

CALCulate:STATe? ==> <OFF | ON>

Queries the state of the math post-processing.

**MeASUREMENT
Subsystem****CONFigure
Subsystem**

The commands in the CONFigure subsystem perform the required configuration of the 2461 TYPE C instrument. The SCALar commands program the 2461 TYPE C for one measurement. The ARRy commands program the counter for multiple measurements as specified by the <array size> parameter. The limit for this parameter is 16384.

The input settings are not changed by these commands. These must be set using the commands in the INPut subsystem.

The reconfiguration of the measurement function invalidates the previously acquired data.

If the CONFigure command is sent while the 2461 TYPE C is initiated, then the measurement in progress is aborted before the reconfiguration takes place.

The CONFigure commands accept the expected value and required resolution parameters. If both these values are specified, and if they are valid, the number of digits of resolution is determined.

CONFigure command summary

COMMAND	Description
CONFigure[1 2 3] :([SCALar] ARRay)	Configures the instrument for:
:VOLTage	
:MINimum	Signal negative peak measurement
:MAXimum	Signal positive peak measurement
:MIDDLE	Trigger level voltage measurement
:FREQuency	Frequency measurement
:FREQuency:RATio	Ratio of frequencies measurement
:FALL:TIME	Fall time measurement
:FTIME	Alias for fall time measurement
:RISE:TIME	Rise time measurement
:RTIME	Alias for rise time measurement
:PERiod	Period measurement
:PWIDth	Positive pulse width measurement
:NWIDth	Negative pulse width measurement
:TINTerval	Time interval measurement
:TOTalize	Totalize measurement
:PHASe	Phase difference between waveforms measurement
:CHECK	Functional tests

CONFigure[1 | 2]:SCALar:VOLTage:MINimum [**<expected value>**, **<resolution>**]

CONFigure[1 | 2]:ARRay:VOLTage:MINimum **<array size>** [**<expected value>**, **<resolution>**]

CONFigure[1 | 2]:SCALar:VOLTage:MAXimum [**<expected value>**, **<resolution>**]

CONFigure[1 | 2]:ARRay:VOLTage:MAXimum **<array size>** [**<expected value>**, **<resolution>**]

CONFigure[1 | 2]:SCALar:VOLTage:MIDDLE [**<expected value>**, **<resolution>**]

CONFigure[1 | 2]:ARRay:VOLTage:MIDDLE **<array size>** [**<expected value>**, **<resolution>**]

DESCRIPTION:

These commands configure the 2461 TYPE C to measure the trigger level voltage on the selected channel. The 2461 TYPE C can be configured to measure the maximum, minimum and mid-point trigger level voltages.

The ARRay commands program the counter for multiple measurements as specified by the <array size> parameter.

The execution of these commands forces the following settings: Auto Trigger is automatically enabled on the selected channel and Common is deselected. The channel trigger level is not updated so when these commands are deselected, the trigger status returns to its previous state.

The optional <expected value> and <resolution> parameters are used to derive the required number of digits of resolution. Their units are volts.

INITIALIZATION: *RST Resolution = 8
Array size = 1

EXAMPLE:

"CONFigure1:VOLTage:MAXimum"

Configures the 2461 TYPE C to measure the maximum (positive peak) trigger level on channel 1 (single measurement).

NO INTERROGATIVE FORM

CONFigure[1 | 2][:SCALar]:FREQUENCY [<expected value>, <resolution>]
CONFigure[1 | 2]:ARRay:FREQUENCY <array size> [,<expected value>, Resolution>]

DESCRIPTION:

These commands configure the 2461 TYPE C to measure the frequency of the signal on the input channel specified.

The ARRay command programs the counter for multiple frequency measurements as specified by the <array size> parameter.

The optional <expected value> and <resolution> parameters are used to derive the required number of digits of resolution. Their units are Hertz.

INITIALIZATION: *RST Resolution = 8
Array size = 1

EXAMPLE:

"CONFigure1:ARRay:FREQuency 100"

Configures the 2461 TYPE C to take 100 frequency measurements on channel 1.

NO INTERROGATIVE FORM

CONFigure[1]:SCALar:FREQuency:RATio [**<expected value>**,
<resolution>]

CONFigure[1]:ARRay:FREQuency:RATio **<array size>**
[,<expected value>, <resolution>]

DESCRIPTION:

These commands configure the 2461 TYPE C to measure the ratio of the frequency of the signal on input channel 1 to the frequency of the signal on input channel 2.

The ARRay command programs the counter for multiple frequency/ratio measurements as specified by the <array size> parameter.

The optional <expected value> and <resolution> parameters are used to derive the required number of digits of resolution. Their have no units. The actual resolution derived by the 2461 TYPE C is determined by both the input signal and the resolution set.

INITIALIZATION: *RST Resolution = 8
Array size = 1

EXAMPLE:

"CONFigure1:ARRay:FREQuency:RATio 50,10E6,1"

Configures the 2461 TYPE C to measure the ratio of the frequencies of the signals on channel 1 and 2 fifty times.

NO INTERROGATIVE FORM

CONFigure[1]:SCALar:FTIME [<expected value>, <resolution>]**CONFigure[1]:ARRay:FTIME** <array size>[,<expected value>,
<resolution>]**CONFigure[1]:SCALar:FALL:TIME** [<expected value>, <resolution>]**CONFigure[1]:ARRay:FALL:TIME** <array size>[,<expected value>,
<resolution>]**CONFigure[1]:SCALar:RTIME** [<expected value>, <resolution>]**CONFigure[1]:ARRay:RTIME** <array size>[,<expected value>,
<resolution>]**CONFigure[1]:SCALar:RISE:TIME** [<expected value>, <resolution>]**CONFigure[1]:ARRay:RISE:TIME** <array size>[,<expected value>,
<resolution>]**DESCRIPTION:**

FTIME and RTIME are aliases for the FALL:TIME and RISE:TIME commands respectively. These commands configure the 2461 TYPE C to measure the fall time and rise time of the signal. The fall time is the period the signal takes to go from 90% to 10% of its peak value. The rise time is the period the signal takes to go from 10% to 90% of its peak value.

The ARRay command programs the counter for multiple rise or fall time measurements as specified by the <array size> parameter.

The execution of these commands forces the following settings: channels 1 and 2 are commoned, the slope selection for each channel is set to positive (for rise time measurement) or negative (for fall time measurement) and auto trigger is selected. The forced settings exist only while this function is selected; when the instrument is set to a basic function, then the previous values of these settings are restored.

The optional <expected value> and <resolution> parameters are used to derive the required number of digits of resolution. Their units are seconds. The actual resolution derived by the 2461 TYPE C is determined by both the input signal and the resolution set.

INITIALIZATION: *RST Resolution = 8
Array size = 1

EXAMPLE:

"CONFigure1:FALL:TIME"

Configures the 2461 TYPE C to measure the fall time of the sig applied to channel 1.

NO INTERROGATIVE FORM

CONFigure[1 | 2]:SCALAR]:PERiod [<EXPECTED VALUE>, <RESOLUTION>]
CONFigure[1 | 2]:ARRay:PERiod <ARRAY SIZE>[,<EXPECTED VALUE>, <RESOLUTION>]

DESCRIPTION:

These commands configure the 2461 TYPE C to measure the period of the signal on the input channel selected.

The ARRay commands program the counter for multiple period measurements as specified by the <array size> parameter.

The optional <expected value> and <resolution> parameters are used to derive the required number of digits of resolution. Their units are seconds.

INITIALIZATION: *RST Resolution = 8
Array size = 1

EXAMPLE:

"CONFigure1:PERiod"

Configures the 2461 TYPE C to measure the period of the signal applied to channel 1.

NO INTERROGATIVE FORM

CONFigure[1]:SCALAR]:PWIDth [<EXPECTED VALUE>, <RESOLUTION>]
CONFigure[1]:ARRay:PWIDth <ARRAY SIZE> [,<EXPECTED VALUE>, <RESOLUTION>]
CONFigure[1]:SCALAR]:NWIDth [<EXPECTED VALUE>, <RESOLUTION>]
CONFigure[1]:ARRay:NWIDth <ARRAY SIZE> [,<EXPECTED VALUE>, <RESOLUTION>]

DESCRIPTION:

These commands configure the 2461 TYPE C to measure the positive or negative pulse width time of the signal on the input channel 1.

The ARRay command programs the counter for multiple pulse width measurements as specified by the <array size> parameter.

The execution of these commands forces the following settings: channel 1 and 2, which are common. The slope selection of channel 1 is set to positive (for positive pulse width measurement) or negative (for negative pulse width measurement), the slope selection of channel 2 is set to negative (for positive pulse width measurement) or positive (for negative pulse width measurement) and auto trigger is selected. The forced settings exist only while this function is selected; when the instrument is set to a basic function, then the previous values of these settings are restored.

The optional <expected value> and <resolution> parameters are used to derive the required number of digits of resolution. Their units are seconds. The actual resolution derived by the 2461 TYPE C is determined by both the input signal and the resolution set.

INITIALIZATION: *RST Resolution = 8
Array size = 1

EXAMPLE:

"CONFigure1:PWIDth 10"

Configures the 2461 TYPE C to measure the positive pulse width of the signal applied to channel 1 (10 measurements).

NO INTERROGATIVE FORM

CONFigure[1 | 2][:SCALar]:TINTerval [<expected value>,
<resolution>]
CONFigure[1 | 2]:ARRay:TINTerval<array size> [,<expected value>,
<resolution>]

NO INTERROGATIVE FORM

**CONFigure[1 | 2][:SCALar]:TOTAlize [<expected value>,
<resolution>]**
**CONFigure[1 | 2]:ARRAy:TOTAlize <array size>[<expected value>,
<resolution>]**

DESCRIPTION:

These commands configure the 2461 TYPE C to totalize events occurring at channels 1 or 2. The counting interval can be controlled by:

(1) Electrical start and stop signals applied to the channel 2 input (Totalize 1 by 2) or to the channel 1 input (Totalize 2 by 1).

(2) Successive operations (Manual Totalize). Refer to the SENSE:TOTAlize:MANual command for a description of the Manual mode.

Note that the arming of the stop circuit can be delayed for a time set by the operator. This prevents the measurement interval being stopped prematurely by spurious pulses, such as those caused by contact bounce. Refer to the SENSE:TINterval:DELAy:TIME and SENSE:TINterval:DELAy:STATe for a description.

The return of intermediate totalize results (reading on the fly) can be enabled by using the SENSE:TOTAlize:INTErmediate command (only for SCALar-type measurements).

The ARRAy command programs the counter for multiple totalize measurements as specified by the <array size> parameter.

The optional <expected value> and <resolution> parameters are accepted but ignored. The resolution is determined by the input signal.

INITIALIZATION: *RST Resolution = 8
Array size = 1

EXAMPLE:

"CONFigure1:TOTalize"

Configures the 2461 TYPE C to totalize events occurring at channel 1 input during the time window defined by signal on channel 2.

NO INTERROGATIVE FORM

CONFigure[1 | 2]:SCALar:PHASe [<expected value>,
<resolution>]
CONFigure[1 | 2]:ARRay:PHASe <array size> [,<expected value>,
<resolution>]

DESCRIPTION:

These commands configure the 2461 TYPE C to measure the phase difference between the waveform applied to the channel 1 input and that applied to the channel 2 input (Phase 1 relative to 2), or between the waveform applied to the channel 2 input and that applied to the channel 1 input (Phase 2 relative to 1).

Note: The phase measurement is aborted and an error is generated if the frequencies of the signals applied to channel 1 and 2 are different.

The ARRay command programs the counter for multiple phase measurements as specified by the <array size> parameter.

The optional <expected value> and <resolution> parameters are accepted but ignored. The units are in degrees. The resolution is determined by the input signal.

INITIALIZATION: *RST Resolution = 8
Array size = 1

EXAMPLE:

"CONFigure2:PHASe 100"

Configures the 2461 TYPE C to measure the phase difference between the waveform applied to the channel 2 input and that applied to channel 1 input.

NO INTERROGATIVE FORM

CONFigure:CHECK[<expected value>, <resolution>]**DESCRIPTION:**

This command connects the standard frequency in use to the counting input and takes frequency measurements. The higher the resolution selected, the longer the gate time and hence more of the counting chain is checked. The result must be 10 MHz exactly for no error. Note that this function can return the error -300 ("Basic self-check failure") in place of the 10MHz result to indicate certain hardware failures.

Note: This function must be selected to perform functional tests. Refer to the commands in the TEST sub-system.

The optional <expected value> and <resolution> parameters are used to derive the required number of digits of resolution. Their units are Hertz.

INITIALIZATION: *RST Resolution = 8
Array size = 1

EXAMPLE:

"CONFigure:CHECK"

Configures the 2461 TYPE C to measure the frequency standard.

NO INTERROGATIVE FORM

CONFigure?

DESCRIPTION:

This query returns the current function, channel and required number of measurements. The function strings returned are:

“FREQ”
“FREQ:RAT”
“VOLT:MAX”
“VOLT:MIN”
“VOLT:MIDD”
“PWID”
“NWID”
“PER”
“RTIM”
“FTIM”
“TINT”
“TOT”
“PHAS”
“CHEC”

EXAMPLE:

“CONFigure?”

This query would return the string “**FREQ1,5**” if the function selected is FREQuency, the current channel is 1 and an ARRay-type measurement (5 samples) was specified.

Initialization: *RST FREQ1,1

FETCh Subsystem

The FETCh subsystem has the function of retrieving the results of a measurement or an array of measurements. If a measurement or an array of measurements has not been completed, the 2461 TYPE C will delay the read until the measurement(s) have completed.

The default value of <count> is the number of measurements specified by the last CONFigure or MEASure? commands. The default value of <start> is 1. The default value for <step> is 1. The number of values returned is <count>. The first of the values returned is value <start>. Then every <step> values after start are returned.

The maximum number of measurement samples that can be retrieved by the FETCh? command is 700. If more measurements have been taken, the FETCh? command is to be sent more than once (every time specifying a different value for the <start> parameter).

If the range of requested values is beyond the number of measurements, an error will be generated and no values returned.

The FETCh? query is rejected with an error if the data is invalid. Data becomes invalid in the following conditions:

- When *RST is executed
- When an INITiate is executed
- When there is any reconfiguration of measurement function, signal routing or trigger blocks

See FETCh command summary on the next page.

COMMAND	DESCRIPTION
<p>FETCh</p> <p>[:VOLTage]? [:MINimum]? [:MAXimum]? [:MIDDle]? [:FREQuency]? [:FREQuency:RATio]? [:FALL:TIME]? [:FTIME]? [:RISE:TIME]? [:RTIME]? [:PERiod]? [:PWIDth]? [:NWIDth]? [:TINTerval]? [:TOTalize]? [:PHASe]? [:CHECK]?</p>	<p>Retrieves the following measurements:</p> <p>Trigger level voltage Minimum trigger level voltage Maximum trigger level voltage Middle trigger level voltage Frequency Ratio of frequencies Fall time Alias for fall time Rise time Alias for rise time Period Positive pulse width Negative pulse width Time interval Totalize Phase difference Functional tests</p>

FETCh? [<count>[,<start>[,<step>]]]

Description:

Returns the result of the previous measurement.

Parameters:

The default value of <count> is the number of measurements for the Array. The default value of <start> is 1. The default value for <step> is 1. The number of values returned is <count>. The first of the values returned is value <start>, and then all <step> values after start are returned.

The reading placed on the VXI output buffer is in exponential form. For example, a 5 Mhz reading will be returned as follows: +00005.0000000E+06. The number of returned bytes in the VXI output buffer is fixed at 18 bytes.

Initialization: Not Applicable

Example:

```
"FETCh? 50,1,2"
```

Returns the results of 50 measurements previously performed. The first value returned is the first measurement. Then every 2 values after the first are returned.

```

FETCh[:VOLTage][:MINimum]? [<count>,<start>,<step>]]]
FETCh[:VOLTage][:MAXimum]? [<count>,<start>,<step>]]]
FETCh[:FREQuency]?          [<count>,<start>,<step>]]]
FETCh[:FREQuency][:RATio]? [<count>,<start>,<step>]]]
FETCh[:FTIME]?              [<count>,<start>,<step>]]]
FETCh[:FALL:TIME]?         [<count>,<start>,<step>]]]
FETCh[:RTIME]?             [<count>,<start>,<step>]]]
FETCh[:RISE:TIME]?        [<count>,<start>,<step>]]]
FETCh[:PERiod]?           [<count>,<start>,<step>]]]
FETCh[:PWIDth]?          [<count>,<start>,<step>]]]
FETCh[:NWIDth]?          [<count>,<start>,<step>]]]
FETCh[:TINTerval]?       [<count>,<start>,<step>]]]
FETCh[:TOTalize]?       [<count>,<start>,<step>]]]
FETCh[:PHASe]?          [<count>,<start>,<step>]]]
FETCh[:CHECK]?          [<count>,<start>,<step>]]]

```

Description:

These commands return the results of the previous measurement(s) taken. The function and the parameters specified must match those of the previous CONFigure or MEASure? commands.

The reading placed in the VXI output buffer is in exponential form. For example, a 5 Mhz reading will be returned as follows: +00005.0000000E+06. The number of returned bytes in the VXI output buffer is fixed at 18 bytes.

Parameters:

The default value of <count> is the number of measurements for the array. The default value of <start> is 1. The default value for <step> is 1. The number of values returned is <count>. The first of the values returned is value <start>, then all <step> values after start are returned.

MEASure Subsystem

The commands in the MEASure subsystem instructs the 2461 TYPE C on the type of measurement to be taken and the input channel to be used. They also initiate the specified measurement(s) and return the results when they complete.

The input settings are not changed by these commands. These must be set using the commands in the INPut subsystem.

The SCALar commands program the 2461 TYPE C for one measurement. The ARRy commands program the counter for multiple measurements as specified by the <array size> parameter. The limit for this parameter is 16384.

If the MEASure command is sent while the 2461 TYPE C is initiated, then measurement in progress is aborted before the reconfiguration takes place.

The MEASure commands accept an expected value and required resolution parameters. If both these values are specified, and if they are valid, then the number of digits of resolution is determined.

The MEASure? command is equivalent to the CONFigure and READ? combination. READ?, in turn, is broken down into two additional commands, INITiate:IMMediate and FETCh?

Note that, in the case of ARRy-type measurement, the time-out period (refer to SYSTem:TIMEout) may have to be increased.

See MEASure command summary on the next page.

COMMAND	DESCRIPTION
:MEASure[1 2 3] :([SCALar] ARRay)	Performs:
:VOLTage	
:MINimum	Trigger level negative peak measurement
:MAXimum	Trigger level positive peak measurement
:MIDDLE	Trigger level voltage measurement
:FREQuency	Frequency measurement
:FREQuency:RATio	Ratio of frequencies measurement
:FTIME	Fall time measurement
:FALL:TIME	Alias for fall time measurement
:RTIME	Rise time measurement
:RISE:TIME	Alias for rise time measurement
:PERiod	Period measurement
:PWIDth	Positive pulse width measurement
:NWIDth	Negative pulse width measurement
:TINTerval	Time interval measurement
:TOTalize	Totalize measurement
:PHASe	Phase difference between waveforms measurement
:CHECK	Functional tests

**MEASure[1 | 2]:[SCALar]:VOLTage:MINimum? [<expected value>
, <resolution>]**

**MEASure[1 | 2]:ARRay:VOLTage:MINimum? <array size>
[,<expected value>, <resolution>]**

**MEASure[1 | 2]:[SCALar]:VOLTage:MAXimum? [<expected
value>,
<resolution>]**

**MEASure[1 | 2]:ARRay:VOLTage:MAXimum? <array size>
[,<expected value>, <resolution>]**

**MEASure[1 | 2]:[SCALar]:VOLTage:MIDDLE? [<expected value>,
<resolution>]**

**MEASure[1 | 2]:ARRay:VOLTage:MIDDLE? <array size>
[,<expected value>, <resolution>]**

DESCRIPTION:

These commands set the 2461 TYPE C to measure the trigger level voltage on the selected channel. The 2461 TYPE C can be instructed to measure the maximum, minimum and mid-point trigger level voltages.

The ARRay command programs the counter for multiple voltage measurements as specified by the <array size> parameter.

The execution of these commands forces the following settings: Auto Trigger is automatically enabled on the selected channel and Common is deselected. The channel trigger level is not updated so when these commands are deselected, the trigger status returns to its previous state.

The optional <expected value> and <resolution> parameters are used to derive the required number of digits of resolution. Their units are volts.

INITIALIZATION: *RST Resolution = 8
Array size = 1

EXAMPLE:

"MEASure2:VOLTage:MAXimum? "

Instructs the 2461 TYPE C to measure the maximum (positive peak) trigger level on channel 2 (single measurement).

**MEASure[1 | 2 | 3]:SCALar:FREQuency? [<expected value>, <resolution>]
MEASure[1 | 2 | 3]:ARRay:FREQuency? <array size> [<expected value>, <resolution>]**

DESCRIPTION:

These commands set the 2461 TYPE C to measure the frequency of the signal on the input channel specified.

The ARRay command programs the counter for multiple frequency measurements as specified by the <array size> parameter.

The optional <expected value> and <resolution> parameters are used to derive the required number of digits of resolution. Their units are Hertz.

INITIALIZATION: *RST Resolution = 8
Array size = 1

EXAMPLE:

"MEASure1:ARRay:FREQuency? 100"

Instructs the 2461 TYPE C to take 100 frequency measurements on channel 1.

**MEASure[1 | 3][:SCALar]:FREQuency:RATio? [<expected value>, <resolution>]
MEASure[1 | 3]:ARRay:FREQuency:RATio? <array size> [, <Expected value>, <resolution>]**

DESCRIPTION:

These commands set the 2461 TYPE C to measure the ratio of frequencies of the signals on input channels 1 and or input channels 3 and 2.

The ARRay command programs the counter for multiple frequency ratio measurements as specified by the <array size> parameter.

The optional <expected value> and <resolution> parameters are used to derive the required number of digits of resolution. They have no units. The actual resolution derived by the 2461 TYPE C is determined by both the input signal and the resolution set.

INITIALIZATION: *RST Resolution = 8
Array size = 1

EXAMPLE:

"MEASure1:ARRay:FREQuency:RATio? 50,10E6,1"

Instructs the 2461 TYPE C to measure the frequencies of the signals on channel 1 and 2 and derive their ratio (50 times).

**MEASure[1][:SCALar]:FTIME? [<expected value>, <resolution>]
MEASure[1]:ARRay:FTIME <array size>? [, <expected value>, <resolution>]
MEASure[1][:SCALar]:FALL:TIME? [<expected value>, <resolution>]
MEASure[1]:ARRay:FALL:TIME <array size>? [, <expected value>, <resolution>]**

MEASure[1][:SCALar]:RTIME? [<expected value>, <resolution>]
MEASure[1]:ARRay:RTIME <array size>? [, <expected value>, <resolution>]
MEASure[1][:SCALar]:RISe:TIME? [<expected value>, <resolution>]
MEASure[1]:ARRay:RISe:TIME <array size>? [, <expected value>, <resolution>]

DESCRIPTION:

FTIME and RTIME are an alias for the FALL:TIME and RISe:TIME commands respectively. These commands set the 2461 TYPE C to measure the fall time and rise time of the signal. The fall time is the period the signal takes to go from 90% to 10% of its peak value. The rise time is the period the signal takes to go from 10% to 90% of its peak value.

The ARRAy commands program the counter for multiple measurements as specified by the <array size> parameter.

The execution of these commands forces the following settings: channels 1 and 2 are commoned, the slope selection for each channel is set to positive (for rise time measurement) or negative (for fall time measurement) and auto trigger is selected. The forced settings exist only while this function is selected; when the instrument is set to a basic function, then the previous values of these settings are restored.

The optional <expected value> and <resolution> parameters are used to derive the required number of digits of resolution. Their units are seconds. The actual resolution derived by the 2461 TYPE C is determined by both the input signal and the resolution set.

INITIALIZATION: *RST Resolution = 8
Array size = 1

EXAMPLE:

"MEASure1:FALL:TIME? "

Instructs the 2461 TYPE C to measure the fall time of the signal applied to channel 1.

MEASure[1 | 2][:SCALar]:PERiod? [<expected value>,
 <resolution>]
 MEASure[1 | 2]:ARRay:PERiod <array size>? [,<expected
 value>, <resolution>]

DESCRIPTION:

These commands set the 2461 TYPE C to measure the period of the signal on the input channel selected.

The ARRay command programs the counter for multiple period measurements as specified by the <array size> parameter.

The optional <expected value> and <resolution> parameters are used to derive the required number of digits of resolution. Their units are seconds.

INITIALIZATION: *RST Resolution = 8

Array size = 1

EXAMPLE:

"MEASure1:Period? "

Instructs the 2461 TYPE C to measure the period of the signal applied to channel 1.

MEASure[1][:SCALar]:PWIDth? [<expected value>, <resolution>]
 MEASure[1]:ARRay:PWIDth?<array size> [,<expected value>,
 <resolution>]
 MEASure[1][:SCALar]:NWIDth? [<expected value>, <resolution>]
 MEASure[1]:ARRay:NWIDth? <array size> [,<expected value>,
 <resolution>]

DESCRIPTION:

These commands set the 2461 TYPE C to measure the positive or negative pulse width time of the signal on the input channel 1.

The ARRay command programs the counter for multiple pulse width measurements as specified by the <array size> parameter.

The execution of these commands forces the following settings: channel 1 and 2 are commoned, the slope selection of channel 1 is set to positive (for positive pulse width measurement) or negative (for negative pulse width measurement), the slope selection of channel 2 is set to negative (for positive pulse width measurement) or positive

(for negative pulse width measurement) and auto trigger is selected. The forced settings exist only while this function is selected; when the instrument is set to a basic function, then the previous values of these settings are restored.

The optional <expected value> and <resolution> parameters are used to derive the required number of digits of resolution. Their units are seconds. The actual resolution derived by the 2461 TYPE C is determined by both the input signal and the resolution set.

INITIALIZATION: *RST Resolution = 8
Array size = 1

EXAMPLE:

"MEASure1:PWIDth? 10"

Instructs the 2461 TYPE C to measure the positive pulse width of the signal applied to channel 1 (10 measurements).

**MEASure[1 | 2][:SCALAr]:TINTerval? [<expected value>, <resolution>]
MEASure[1 | 2]:ARRAy:TINTerval?<array size> [<expected value>, <resolution>]**

DESCRIPTION:

These commands set the 2461 TYPE C to make single-shot measurements of the time interval between:

- (1) An event occurring at the Channel 1 input and a later event at the channel 2 input (using separate input channels).
- (2) An event occurring at the Channel 2 input and a later event at the channel 1 input (using separate input channels).
- (3) Two events occurring at the channel 1 input (using a common input channel).

The channel specified selects the input channel for the beginning of the interval.

The trigger slopes for the start and stop can be either positive or negative.

The ARRAy command programs the counter for multiple time interval measurements as specified by the <array size>

parameter.

The optional <expected value> and <resolution> parameters are used to derive the required number of digits of resolution. Their units are seconds. The actual resolution derived by the 2461 TYPE C is determined by both the input signal and the resolution set.

INITIALIZATION: *RST Resolution = 8

Array size = 1

EXAMPLE:

"MEASure2:TINTerval? "

Instructs the 2461 TYPE C to make a time interval measurement between an event on channel 2 and a following event on channel 1 (assuming that separate input channels are being used).

MEASure[1 | 2][:SCALar]:TOTAlize? [<expected value>, <resolution>]

MEASure[1 | 2]:ARRAy:TOTAlize? <array size> [,<expected value>, <resolution>]

DESCRIPTION:

These commands set the 2461 TYPE C to totalize events occurring at channel 1 or 2. The counting interval is controlled by electrical start and stop signals applied to the channel 2 input (Totalize 1 by 2) or to the channel 1 input (Totalize 2 by 1). These commands cannot be used to take Manual Totalize measurements (refer to SENSE:TOTAlize:MANual ON | OFF).

Note that the arming of the stop circuit can be delayed for a time set by the operator. This prevents the measurement interval being stopped prematurely by spurious pulses, such as those caused by contact bounce. Refer to the SENSE:TINTerval:DELAy:TIME and SENSE:TINTerval:DELAy:STATe for a description.

The return of intermediate totalize results (reading on the fly) can be enabled by using the SENSE:TOTAlize:INTermediate

command (only for SCALAr-type measurements).

The ARRAy command programs the counter for multiple totalize measurements as specified by the <array size> parameter.

The optional <expected value> and <resolution> parameters are accepted but ignored. The resolution is determined by the input signal.

INITIALIZATION: *RST Resolution = 8
Array size = 1

EXAMPLE:

"MEASure1:TOTalize? "

Instructs the 2461 TYPE C to totalize events occurring at channel 1 input during the time window defined by signal on channel 2.

**MEASure[1 | 2][:SCALAr]:PHASe? [<expected value>,
<resolution>]
MEASure[1 | 2]:ARRAy:PHASe? <array size> [,<expected value>,
<resolution>]**

DESCRIPTION:

These commands set the 2461 TYPE C to measure the phase difference between the waveform applied to the channel 1 input and that applied to the channel 2 input (Phase 1 relative to 2), or between the waveform applied to the channel 2 input and that applied to the channel 1 input (Phase 2 relative to 1).

The ARRAy command programs the counter for multiple measurements as specified by the <array size> parameter.

The optional <expected value> and <resolution> parameters are accepted but ignored. Their units are in degrees. The resolution is determined by the input signal.

INITIALIZATION: *RST Resolution = 8
Array size = 1

EXAMPLE:

```
"MEASure2:PHASe? 100"
```

Instructs the 2461 TYPE C to measure the phase difference between the waveform applied to the channel 2 input and that applied to channel 1 input.

```
*****
```

```
MEASure:CHECK? [<expected value>, <resolution>]
```

DESCRIPTION:

This command connects the standard frequency in use to the counting input and takes frequency measurements. The higher the resolution selected, the longer the gate time and hence more of the counting chain is checked. The result must be 10 MHz exactly for no error. Note that this function can return the error -300 ("Basic self-check failure") in place of the 10MHz result to indicate certain hardware failures.

The optional <expected value> and <resolution> parameters are used to derive the required number of digits of resolution. Their units are Hertz.

```
INITIALIZATION: *RST Resolution = 8
                  Array size = 1
```

EXAMPLE:

```
"MEASure:CHECK? "
```

Instructs the 2461 TYPE C to measure the standard frequency and returns the result of the measurement.

```
MEASure? [<expected value>, <resolution>]
```

DESCRIPTION:

Starts a new measurement cycle without re-configuring the instrument's measurement function (i.e. the function used is that specified by the last CONFIGure, SENSE or MEASure command). Similarly, the number of measurements taken depend on the <array size> parameter previously specified with the last CONFIGure or MEASure commands.

The optional <expected value> and <resolution> parameters are used to derive the required number of digits of resolution. Their units depend on the currently selected measurement

function.

INITIALIZATION: *RST Resolution = 8
Array size = 1

EXAMPLE:

"MEASure? 1000000,10"

Initiates a new measurement cycle on the currently selected function. The <expected value> and <resolution> parameters specify 6 digits of resolution.

READ Subsystem

READ command summary

COMMAND	DESCRIPTION
READ?	Initiates a measurement and returns the value.

READ?**Description:**

Causes an INITiate:IMMEDIATE action followed by a FETCh? query. INITiate:IMMEDIATE performs the data acquisition, while FETCh? returns the measurement.

The measurement function must be selected using the CONFigure:FUNCTION, SENSE:FUNCTION or MEASure:FUNCTION? commands.

The number of measurements taken and returned depend on the <array size> parameter specified in the last CONFigure:ARRAY or MEASure:ARRAY commands. Only one measurement is taken if the last CONFigure or MEASure command specified a SCALAR-type measurement.

Note that, in the case of ARRAY-type measurement, the time-out period (refer to SYSTem:TIMEout) may have to be increased.

Initialization: Not Applicable

Example:

```
READ?
```

```
Initiates and retrieves a measurement on the selected
function
```

INPut Subsystem

The INPut subsystem has the function of specifying some of the characteristics of the 2461 TYPE C, such as attenuation, coupling, impedance, etc. The query form of these commands returns the setting previously specified.

INPut command summary

COMMAND	DESCRIPTION
INPut[1 2]	
:ATTenuation	Selects x1 or X10 attenuation.
:COUPLing	Selects AC or DC coupling.
:IMPedance	Selects 50Ω or 1MΩ input impedance.
:ROUte	Separates or commons input channels 1 and 2.
:FILTer	
[:LPASs]	
[:STATe]	Enables or disables the low-pass filter.
:COMParator	
:LEVel	
:RELative	Selects relative trigger voltage level.
[:ABSolute]	Selects absolute trigger voltage level.
:HYSteresis	
:RELative	Enables or disables hysteresis.
:SLOPe	Selects comparator slope.
:SETup	
:AUTO	Enables, continuously or singly, or disables auto trigger.
:FREQuency	Selects the minimum frequency the auto trigger algorithm will detect reliably.

INPut[1 | 2]:ATTenuation <value | MINimum | MAXimum | DEFault>

DESCRIPTION:

Selects the input block signal attenuator for the specified channel. If the numerical <value> is less than or equal to 2, the attenuator is set to 1. If <value> is greater than 2, the attenuator is set to 10.

If this command is received while the functions VOLTage:MIDDLE, VOLTage:MAXimum, VOLTage:MINimum, RISE:TIME, FALL:TIME, PWIDTH and NWIDTH are active, then the error -240 is generated

("Function Error").

If this command is received while the functions FREQuency, PERiod, TIME:INTerval, TOTalize, FREQuency:RATio and CHECk are active, then, in addition to the setting of the attenuation level, the following is set:

- If channel 1 is specified, then manual trigger is set for channel 1;
- If channel 2 is selected and SEParate is specified, then manual trigger is set for channel 2.

PARAMETERS:

$0 \leq \text{value} \leq 10E6$

MIN = 1

MAX = 10

DEFault = 1 (x1 attenuation)

INITIALISATION:

*RST 1

INTERROGATIVE FORM

INPut[1 | 2]:ATTenuation? ==> <1 | 10>

Returns the current attenuation setting for the specified channel (1 or 10).

INPut[1 | 2]:COUPling <AC | DC | DEFault>

DESCRIPTION:

Selects the input coupling for the specified channel.

PARAMETERS:

DEFault = AC

INITIALIZATION:

*RST AC

INTERROGATIVE FORM

INPut[1 | 2]:COUPling? ==> <AC | DC>

Returns the current coupling setting for the specified channel.

INPut[1 | 2]:IMPedance <value | MINimum | MAXimum | DEFault>

DESCRIPTION:

Selects the input terminating impedance for the specified channel. If <value> is less than 60, the impedance is set to 50 Ω. If <value> is greater than 60, the impedance is set to 1M Ω.

PARAMETERS:

$0 \leq \text{value} \leq 10E6\Omega$
MIN = 50Ω
MAX = 1E6Ω
DEFault = 1E6Ω

INITIALIZATION:

*RST MAX

INTERROGATIVE FORM

INPut[1 | 2]:IMPedance? ==> <50 | 1000000>

Returns the current impedance setting for the specified channel.

INPut[1 | 2]:ROUte <SEParate | COMMon | DEFault>

DESCRIPTION:

Connects or separates input channel 1 and 2. When COMMON is specified, the signal at channel 1 is connected to both channels. When this is done, the channel 2 input socket is isolated from channel 2.

If COMMON is specified while the functions VOLTage:MIDDLE, VOLTage:MAXimum and VOLTage:MINimum are active, then the error -240 is generated ("Function Error").

If SEPARate is specified while the functions PHASe, RISE:TIME, FALL:TIME, PWIDTH and NWIDTH are active, then the error -240 is generated ("Function Error").

PARAMETERS:

DEFault = SEP

INITIALIZATION:

*RST SEP

INTERROGATIVE FORM

INPut[1 | 2]:ROUTe? ==> <SEParate | COMMON>

Returns the current input route setting.

If the functions VOLTage:MIDDLE, VOLTage:MAXimum and VOLTage:MINimum are active, then the query returns SEPARate.

If the functions PHASe, RISE:TIME, FALL:TIME, PWIDTH and NWIDTH are active, then the query returns COMMON.

INPut[1 | 2]:FILTer[:LPASs][:STATe] <ON | OFF | DEFault>

DESCRIPTION:

Selects the input block signal low-pass filter state for the specified channel to ON or OFF.

PARAMETERS:

DEFault = OFF

INITIALIZATION:

*RST OFF

INTERROGATIVE FORM

INPut[1 | 2]:FILTer[:LPASs][:STATe]? ==> <ON | OFF>

Returns the current low-pass filter setting for the specified channel.

INPut[1 | 2]:COMParator:LEVel:RELative <value | MINimum | MAXimum | DEFault>

DESCRIPTION:

Selects the comparator threshold level voltage of the channel selected. The unit for <value> is Volt.

If value is in the range -5.1 to +5.1, then x1 attenuation is selected for that channel. Outside this range x10 is selected. Auto trigger is de-selected.

If this command is received while the functions RISE:TIME, FALL:TIME, PWIDTH and NWIDTH are active, then the error -240 is generated ("Function Error").

If this command is received while the functions FREQUENCY, PERIOD, TINTERVAL, TOTALIZE, FREQUENCY:RATIO and CHECK are active, then, in addition to the setting of the attenuation level, the following is set:

- If channel 1 is specified, then manual trigger is set for channel 1;
- If channel 2 is selected and SEPARATE is specified, then manual trigger is set for channel 2.
- If channel 2 is selected and COMMON is specified, then manual trigger is set for channel 1.

If this command is sent while the functions PHASE, RISE:TIME, FALL:TIME, PWIDTH and NWIDTH are active, then the error -240 is generated ("Function Error").

If this command is sent while the functions VOLT:MAX, VOLT:MIN and VOLT:MIDD are active and the channel specified is the same as the channel currently configured for

the measurement function, then the error -240 is generated ("Function Error").

PARAMETERS:

-51.2 ≤ value ≤ 51.2
DEFAult = 0
MIN = -51.2
MAX = 51.2

INITIALIZATION: N/A

INTERROGATIVE FORM

INPut[1 | 2]:COMParator:LEVel:RELative? ==> <relative comparator level>

Returns the current comparator absolute level multiplied by the current attenuation value setting for the specified channel.

INPut[1 | 2]:COMParator:LEVel[:ABSolute] <value | MINimum | MAXimum | DEFAult>

DESCRIPTION:

Selects the comparator threshold level voltage of the channel selected. The unit for <value> is Volt.

Auto trigger is de-selected.

If this command is received while the functions RISE:TIME, FALL:TIME, PWIDTH and NWIDTH are active, then the error -240 is generated ("Function Error").

If this command is received while the functions FREQuency, PERiod, TINTerval, TOTalize, FREQuency:RATio and CHECk are active, then, in addition to the setting of the

attenuation level, the following is set:

- If channel 1 is specified, then manual trigger is set for channel 1;
- If channel 2 is selected and SEParate is specified, then manual trigger is set for channel 2.
- If channel 2 is selected and COMMOon is specified, then manual trigger is set for channel 1.

If this command is received while the functions PHASe, RISE:TIME, FALL:TIME, PWIDTH and NWIDTH are active, then the error -240 is generated ("Function Error").

If this command is received while the functions VOLT:MAX, VOLT:MIN and VOLT:MIDD are active and the channel specified is the same as the channel currently configured for the measurement function, then the error -240 is generated ("Function Error").

PARAMETERS:

-5.1 ≤ value ≤ 5.1

DEFault = 0

MIN = -5.1

MAX = 5.1

INITIALIZATION:

*RST 0

INTERROGATIVE FORM

INPut[1 | 2]:COMParator:LEVel[:ABSolute]? ==>
<comparator level>

Returns the current comparator level setting for the specified channel. Note that the attenuation setting is ignored.

.....

**INPut[1 | 2]:COMParator:HYSTeresis:RELative
<MINimum | MAXimum | DEFault>**

DESCRIPTION:

This command selects the hysteresis voltage for the selected input channel and comparator.

PARAMETERS:

DEFault = MIN

MAX = High level

MIN = Low level

INITIALIZATION:

*RST MIN

INTERROGATIVE FORM

INPut[1 | 2]:COMParator:HYSTeresis:RELative? ==>
<MINimum | MAXimum>

Returns the current hysteresis setting (high or low level).

INPut[1 | 2]:COMParator:SLOPe <POSitive | NEGative | DEFault>**DESCRIPTION:**

Selects the slope for the channel and comparator selected. The slope may be either positive or negative.

If NEGative is specified while the function RISE:TIME is active, then the error -240 is generated ("Function Error").

If POSitive or DEFault are specified while the function FALL:TIME is active, then the error -240 is generated ("Function Error").

If POSitive or DEFault are specified while the function PWIDTH is active and channel 2 is specified, then the error -240 is generated ("Function Error").

If NEGative is specified while the function PWIDTH is active and channel 1 is specified, then the error -240 is generated ("Function Error").

PARAMETERS:

DEFault = POS

INITIALIZATION:

*RST POS

INTERROGATIVE FORM

INPut[1 | 2]:COMParator:SLOPe? ==> <POSitive |
NEGative>

Returns the current comparator slope setting for the specified channel.

If the function RISE:TIME is active, the query returns POS.

If the function FALL:TIME is active, the query returns NEG.

If the function PWIDth is active, the query returns POS if channel 1 is specified, or NEG if channel 2 is specified.

If the function NWIDth is active, the query returns POS if channel 2 is specified, or NEG if channel 1 is specified.

**INPut[1 | 2]:COMParator:SETup:AUTO <ON | OFF | ONC
DEFault>**

DESCRIPTION:

Enables, either continuously or singly, or disables the auto trigger.

If OFF, ONCE or DEFault are specified while the functions PHASe, RISE:TIME, FALL:TIME, PWIDth and NWIDth are active, then the error -240 is generated ("Function Error").

If OFF, ONCE or DEFault are specified while the functions VOLT:MAX, VOLT:MIN and VOLT:MIDD are active and the channel specified is the same as the channel currently configured for the measurement function, then the error -240 is generated ("Function Error").

PARAMETERS:

DEFault = OFF

INITIALIZATION:

*RST OFF

INTERROGATIVE FORM

INPut[1 | 2]:COMParator:SETup:AUTO? ==> <ON | OFF | ONCE>

Returns the current auto trigger setup setting for the specified channel.

If the functions PHASe, RISE:TIME, FALL:TIME, PWIDth and NWIDth are active, then the query returns ON.

If the functions VOLT:MAX, VOLT:MIN and VOLT:MIDD are active, then the query returns ON if the channel specified is the same as the channel currently configured for the measurement function.

.....

**INPut[1 | 2]:COMParator:SETup:AUTO:FREQuency
<MINimum|MAXimum|DEFault>**

DESCRIPTION:

Selects the minimum frequency the auto trigger algorithm will detect reliably for the purpose of speeding the auto trigger function.

PARAMETERS:

DEFault = MAX

MIN = 50Hz

MAX = 1000Hz

INITIALIZATION:

*RST 1000Hz

INTERROGATIVE FORM

INPut[1 | 2]:COMParator:SETup:AUTO:FREQuency? ==>
<MINimum|MAXimum>

Returns the current minimum frequency setting for the auto trigger.

SENSE SUBSYSTEM

The commands in the SENSE subsystem perform the required configuration of the 2461 TYPE C instrument (measurement function and other settings). The reconfiguration of the measurement function invalidates the previously acquired data.

If the SENSE:FUNCTION command is sent while the 2461 TYPE C is initiated, then measurement in progress is aborted before the reconfiguration takes place SENSE command summary

COMMAND	DESCRIPTION
[:SENSE[1 2 3]] :FUNCTION	Selects measurement function: "PERiod", "FREQuency ", "FREQuency:RATio", "TINTerval", "RTIME", "RISE:TIME", "FTIME", "FALL:TIME", "PWIDth", "NWIDth", "PHASe", "CHECK", "TOTAlize", "VOLTage:MAXimum", "VOLTage:MINium", "VOLTage:MIDDLE"
[SENSe] [:PERiod]:APERture [:FREQuency]:APERture [:FREQuency:RATio]:APERture [:TINTerval]:APERture [:RTIME]:APERture [:RISE:TIME]:APERture [:FTIME]:APERture [:FALL:TIME]:APERture [:PWIDth]:APERture [:NWIDth]:APERture [:PHASe]:APERture [:TOTAlize]:APERture [:CHECK]:APERture	Selects the measurement aperture (gate time). The function parameter is optional because the aperture value applies to all functions.
:AVERAGE[:STATE] :TINTerval :DELay :TIME [:STATE]	Enables or disables average. Selects time delay. Enables or disables time interval delay.
:TOTAlize :GATe [:STATE] :POLarity	Selects TOTAlize 1 by 2, 2 by 1 or Manual Totalize. Selects slope of channel.
:INTermediate [:STATE] :MANual :RESolution	Enables or disables intermediate results of totalize function Starts and stops Manual Totalize Specifies number of digits of resolution.

<code>[:SENSe[1 2 3]]:FUNction</code>	<code>"FREQuency "</code>
<code>[:SENSe[1 3]]:FUNction</code>	<code>"FREQuency:RATio"</code>
<code>[:SENSe[1 2]]:FUNction</code>	<code>"PERiod "</code>
<code>[:SENSe[1 2]]:FUNction</code>	<code>"VOLTage:MAXimum"</code>
<code>[:SENSe[1 2]]:FUNction</code>	<code>"VOLTage:MINimum"</code>
<code>[:SENSe[1 2]]:FUNction</code>	<code>"VOLTage:MIDDLE"</code>
<code>[:SENSe[1 2]]:FUNction</code>	<code>"TINTerval"</code>
<code>[:SENSe[1]]:FUNction</code>	<code>"RTIME"</code>
<code>[:SENSe[1]]:FUNction</code>	<code>"RISE:TIME"</code>
<code>[:SENSe[1]]:FUNction</code>	<code>"FTIME"</code>
<code>[:SENSe[1]]:FUNction</code>	<code>"FALL:TIME"</code>
<code>[:SENSe[1]]:FUNction</code>	<code>"TOTalize"</code>
<code>[:SENSe[1]]:FUNction</code>	<code>"PWIDth"</code>
<code>[:SENSe[1]]:FUNction</code>	<code>"NWIDth"</code>
<code>[:SENSe[1]]:FUNction</code>	<code>"PHASe"</code>
<code>[:SENSe]:FUNction</code>	<code>"CHECK"</code>

Description:

The SENSE:FUNCTion command selects a function and input channel without changing most of the settings of the counter.

Initialization:

*RST Frequency measurement function selected.

Example:

```
"SENSe1:FUNction  FREQuency "
```

Selects the frequency measurement function on channel 1.

Interrogative form:

```
[:SENSe[1 | 2]]:FUNction? ==> <Function String> (string in short form).
```

Returns a string describing the currently selected function on the specified channel. The possible strings are:

```
"FREQ"
"FREQ:RAT"
"VOLT:MAX"
"VOLT:MIN"
"VOLT:MIDD"
"PWID"
"NWID"
"PER"
"RTIM"
"FTIM"
```

"TINT"
 "TOT"
 "PHAS"
 "CHEC"

Note: If the specified channel is different from the channel previously configured, the 2461 TYPE C returns an error ("Channel not configured").

```
[SENSe][:PERiod]:APERture MINimum | MAXimum | DEFault |
<value>
[SENSe][:FREQuency]:APERture MINimum | MAXimum |
DEFault | <value>
[SENSe][:FREQuency:RATio]:APERture MINimum | MAXimum |
DEFault | <value>
[SENSe][:TINTerval]:APERture MINimum | MAXimum | DEFault
| <value>
[SENSe][:RTIME]:APERture MINimum | MAXimum | DEFault |
<value>
[SENSe][:RISE:TIME]:APERture MINimum | MAXimum |
DEFault | <value>
[SENSe][:FTIME]:APERture MINimum | MAXimum | DEFault |
<value>
[SENSe][:FALL:TIME]:APERture MINimum | MAXimum |
DEFault | <value>
[SENSe][:PWIDth]:APERture MINimum | MAXimum | DEFault |
<value>
[SENSe][:NWIDth]:APERture MINimum | MAXimum | DEFault |
<value>
[SENSe][:PHASe]:APERture MINimum | MAXimum | DEFault |
<value>
[SENSe][:TOTAlize]:APERture MINimum | MAXimum | DEFault
| <value>
[SENSe][:CHECK]:APERture MINimum | MAXimum | DEFault |
<value>
```

Description:

These commands all do the same thing. They set the 2461 TYPE C measurement aperture <time>. The units are seconds and range from 1E-6 to 10. If the user specifies a value, then this will be rounded up or down to the nearest of 1µs, 10µs, 100µs, 1ms, 10ms, 100ms, 1s or 10s.

Note that the aperture for the phase and totalize function is determined by the input signal alone.

The resolution setting may be changed indirectly by the CONFigure:ARRAy and MEASure:ARRAy commands and by the SENSe:RESolution command.

Parameter:

MIN = 1E-6 s

MAX = 10s

DEFault = 1s

1E-6 < value < 10

Initialization:

*RST 0.1s

Example:

"SENSe:APERture 0.6"

The aperture value is rounded to 1s

Interrogative form:

[:SENSe]:APERture? ==> <aperture time>

Returns the aperture time selected.

[SENSe]:AVERage[:STATe] <ON | OFF>**Description:**

Enables or disables the averaging of measurement results. When the average function is enabled, the 2461 TYPE C takes 100 measurements and derives the average value. Note that the resolution increases by one digit when this function is enabled.

NOTE: This function is only available with frequency (on channel 1 and channel 2), period, ratio and time interval measurements.

Initialization:

*RST OFF

Example:

"SENSe:AVERage ON"

Enables averaging.

Interrogative form:

[[:SENSe:]]AVERAge? ==> <ON|OFF>

Returns the state of the AVERAge function.

[SENSe]:TINterval:DELay:TIME <MINinum | MAXimum | value>

Description:

Sets the time delay interval used for time interval and totalize measurements. The selection of a delay prevents the measurement interval from being stopped prematurely by spurious pulses.

If <value> is specified for the time delay interval, then this will be rounded up or down to the nearest 16 microseconds.

Parameter:

MIN = 192E-6s

MAX = 1.04856s

DEF = MIN

Initialization

*RST MIN

Example:

"SENSe:TINterval:DELay:TIME MAX"

Selects maximum time delay interval.

Interrogative form:

[[:SENSe]:]TINterval:DELay:TIME? ==> <time
delay
interval>

Returns the time delay selected.

[SENSe]:TINteRval:DELay[:STATe] <ON | OFF>

Description:

Enables or disables the time interval delay facility. The selection of a delay prevents the measurement interval from being stopped prematurely by spurious pulses.

Initialization:

*RST OFF

Example:

"SENSe:TINteRval:DELay ON"

Selects time interval delay on.

Interrogative form:

[:SENSe]: TINteRval:DELay?: ==> <ON | OFF>

Returns the state of the time interval delay selection.

[SENSe]:TOTAlize:GATE[:STATe] <ON | OFF>

Description:

Enables Automatic Totalize (Totalize 1 by 2 or Totalize 2 by 1) or Manual Totalize. When ON, Automatic Totalize is selected. When OFF, Manual totalize is selected.

This function is only available if the currently selected function is TOTAlize. Sending this command while another measurement function is selected generates the error -240 ("Function not allowed").

Initialization:

*RST ON

Example:

"CONF2:TOT"

"SENSe:TOTAlize:GATE ON"

Selects the Totalize 2 by 1 measurement function..

Interrogative form:

SENSe:TOTAlize:GATE:STATe? ==> <ON | OFF>

Returns the current state of the totalize function.

**[SENSe[1 | 2]]:TOTAlize:GATe:POLArity <NORMAl |
INVerted>**

Description:

Selects the slope of the selected channel. NORM selects a positive slope, and INV selects a negative slope.

This function is only available if the currently selected function is TOTAlize. Sending this command while another measurement function is selected generates the error -240 ("Function not allowed").

Initialization:

*RST NORM (both channel 1 and 2).

Example:

CONF1:TOT

"SENSe2:TOTAlize:GATE:POLArity INV"

Selects a negative polarity for channel 2 (the gating channel).

Interrogative form:

SENSe1:TOTAlize:GATe:POLArity? ==>
<NORMAl | INVerted>

Returns the slope polarity of channel 1.

[SENSe[1 | 2]]:TOTAlize:INTermediate <ON | OFF | DEF>

DESCRIPTION:

Enables or disables intermediate (i.e. on the fly) totalize measurements. If this feature is enabled, FETCh? queries sent during the totalize measurement will return the last intermediate result.

This function is only available if the currently selected function is TOTAlize. Sending this command while another measurement function is selected generates the error –240 (“Function not allowed”).

INITIALIZATION:

*RST OFF

EXAMPLE:

”SENSE1:TOTAlize:INTermediate ON

Enables totalize on the fly measurements.

INTERROGATIVE FORM:

SENSE1:TOTAlize:INTermediate? ==> <ON | OFF>

Returns the current state of the totalize on the fly function.

[SENSE[1 | 2]]:TOTAlize:MANual <ON | OFF>**Description:**

The Manual Totalize function enables the counting of events on either channel 1 or 2. The counting is started with the SENSE:TOTAlize:MANual ON command, and it is stopped with the SENSE:TOTAlize:MANual OFF command. The counting of the manual totalize function is cumulative. The count is reset by the SENSE:TOTAlize:GATE OFF command.

Note: That the readings on-the-fly are automatically enabled.

This function is only available if the currently selected function is TOTAlize. Sending this command while another measurement function is selected generates the error –240 (“Function not allowed”).

Initialization:

*RST OFF

Example:

CONFigure2:TOTAlize Selects TOTAlize function;

SENSE:TOTAlize:GATE OFF Enables Manual
Totalize;

SENSE2:TOTAlize:MANual ON Starts the counting

FETCh? ---> 155	Returns an intermediate count
SENSe2:TOTAlize:MANual OFF	Stops the counting
FETCh? ->>235	Returns the final count
SENSe2:TOTAlize:MANual ON	Re-starts the counting
FETCh? ---> 275	Returns an intermediate count
SENSe2:TOTAlize:MANual OFF	Stops the counting
FETCh? ->>395	Returns the final count
SENSe:TOTAlize:GATE OFF	Resets the count

Interrogative form:

SENSe1:TOTAlize:MANual? ==> <ON | OFF>

Returns the current state of the Manual Totalize function.

[SENSe]:RESolution <value | MINimum | maximum | DEFault>

Description:

Selects the number of digits of resolution. This is in the range of 3 to 10.

In frequency, period, ratio and check modes, the gate time is set by the resolution selected. The resolution of phase and totalize measurements is determined by the input signal.

The resolution setting may be changed indirectly by the CONFigure:ARRay and MEASure:ARRay commands and by the SENSe:APERture command.

Initialization:

*RST 9

Parameters:

3 ≤ value ≤ 10

MIN = 3

MAX = 10

DEF = 8

Example:

"SENSe:RESolution 6"

Selects 6 as the number of digits of resolution.

Interrogative form:

SENSe:RESolution? <Number of digits>

Returns the current number of digits of resolution.

**SOURCE
SUBSYSTEM**

SOURCE command summary

COMMAND	DESCRIPTION
SOURCE :ROSCillator [:SOURCE]	Selects the source of the 2461 TYPE C 10 MHz reference oscillator.

SOURCE:ROSCillator[:SOURCE] <CLOCK10 | INTERNAL | EXTERNAL | DEFAULT>

Description:

This command selects the source of the 2461 TYPE C 10 MHz reference oscillator. Valid sources are the on-board 10 MHz reference (INTERNAL), the VXIbus backplane 10 MHz signal (CLOCK10), and an external source (EXTERNAL).

Parameter:

DEF = CLOCK10

Initialization:

*RST CLOCK10

Example:

SOURCE:ROSCillator:SOURCE EXTERNAL

Selects an external source for the 2461 TYPE C reference oscillator.

Interrogative form:

SOURCE:ROSCillator:SOURCE? ==> <CLOCK10 | INTERNAL | EXTERNAL >

Returns the current source for the reference oscillator.

TEST SUBSYSTEM

TEST command summary

COMMAND	DESCRIPTION
TEST[1 2]	
:RELy	Test 2461 TYPE C relays.
:TEC	
:SHORT	
[:STATe]	Test short period TEC.
:LONG	
[:STATe]	Test long period TEC.
:DAC	
[:STATe]	Test ramp trigger DACs

TEST[1 | 2]:RELy <OFF | ON>**Description:**

This command checks the operation of the input relay for the specified channel. Note that this test can only be performed when the CHECK function is selected.

Use of this command requires an external connection between channel 1 or 2 and the standard output socket on the front panel using a 50Ω coax cable.

The test returns one of the following results:

- 0: Test Passed
- 51: Test Failed:Channel 1 Attenuator relay
- 52: Test Failed:Channel 1 Impedance relay
- 53: Test Failed:Channel 1 AC/DC relay
- 54: Test Failed:Channel 1 Filter relay
- 55: Test Failed:Common relay
- 56: Test Failed:Channel 2 Attenuator relay
- 57: Test Failed:Channel 2 Impedance relay
- 58: Test Failed:Channel 2 AC/DC relay
- 59: Test Failed:Channel 2 Filter relay

Reception of this command turns off all other states in the TEST subtree.

Note that the timeout period (refer to SYSTem:TIMEout) may need to be increased when using the TEST commands.

Initialization:

*RST OFF

Example:

"TEST1:RELAY ON"

Tests channel 1 relay.

Interrogative form:

TEST[1 | 2]:RELay [:STATe]? ==> <ON|OFF>

Returns the current state of the relay.

TEST1:TEC:SHORT[:STATe] <OFF | ON>

Description:

This command checks the functionality of the measurement **start** TEC (Timing Error Correction) circuit using a short calibration pulse. Note that this test can only be performed when the CHECK function is selected.

On reception of this command, the 2461 TYPE C checks the operation of the TEC circuit continuously until the state is turned off, another state is turned on, or the CHECK function is de-selected. The number of test results stored in the main buffer depends on the <array_size> parameter specified by the last CONFigure:ARRay:CHECK or MEASure:ARRay:CHECK? command sent (only one test result is stored if the last CONFigure or MEASure command sent was of SCALar type). Note that while the test state is on, the measurement buffer is constantly updated with new test results.

The value of the test results is a count of pulses, the absolute value of which is relatively unimportant. However, the results obtained must be stable.

Reception of this command turns off all other states in the TEST subtree.

Initialization:

*RST OFF

Example:

"TEST1:TEC:SHORT ON"

Tests start TEC circuit using a short calibrate pulse.

Interrogative form:

TEST[1 | 2]:TEC:SHORT[:STATe] ==> <ON | OFF>

Returns the current state of the test.

TEST2:TEC:SHORT[:STATe] <OFF | ON>

Description:

This command checks the functionality of the measurement **stop** TEC (Timing Error Correction) circuit using a short calibration pulse. Note that this test can only be performed when the CHECK function is selected.

On reception of this command, the 2461 TYPE C checks the operation of the TEC circuit continuously until the state is turned off, another state is turned on, or the CHECK function is de-selected. The number of test results stored in the main buffer depends on the <array_size> parameter specified by the last CONFIGure:ARRay:CHECK or MEASure:ARRay:CHECK? command sent (only one test result is stored if the last CONFIGure or MEASure command sent was of SCALAR type). Note that while the test state is on, the measurement buffer is constantly updated with new test results.

The value of the test results is a count of pulses, the absolute value of which is relatively unimportant. However, the results obtained must be stable.

Reception of this command turns off all other states in the TEST subtree.

Initialization:

*RST OFF

Example:

"TEST2:TEC:SHORT ON"

Tests stop TEC circuit using a short calibrate pulse.

Interrogative form:

TEST2:TEC:SHORT[:STATe] ==> <ON | OFF>

Returns the current state of the test.

TEST1:TEC:LONG[:STATe] <OFF | ON>

Description:

This command checks the functionality of the measurement **start** TEC (Timing Error Correction) circuit using a long calibration pulse. Note that this test can only be performed when the CHECK function is selected.

On reception of this command, the 2461 TYPE C checks the operation of the TEC circuit continuously until the state is turned off, another state is turned on, or the CHECK function is de-selected. The number of test results stored in the main buffer depends on the <array_size> parameter specified by the last CONFIGure:ARRAY:CHECK or MEASURE:ARRAY:CHECK? command sent (only one test result is stored if the last CONFIGure or MEASURE command sent was of SCALAR type). Note that while the test state is on, the measurement buffer is constantly updated with new test results.

The value of the test results is a count of pulses, the absolute value of which is relatively unimportant. However, the results obtained must be stable.

Reception of this command turns off all other states in the TEST subtree.

Initialization:

*RST OFF

Example:

"TEST1:TEC:LONG ON"

Tests start TEC circuit using a long calibrate pulse.

Interrogative form:

TEST1:TEC:LONG[:STATe] ==> <ON | OFF>

Returns the current state of the test.

TEST2:TEC:LONG[:STATe]**<OFF | ON>****Description:**

This command checks the functionality of the measurement **stop** TEC (Timing Error Correction) circuit using a long calibration pulse. Note that this test can only be performed when the CHECK function is selected.

On reception of this command, the 2461 TYPE C checks the operation of the TEC circuit continuously until the state is turned off, another state is turned on, or the CHECK function is de-selected. The number of test results stored in the main buffer depends on the <array_size> parameter specified by the last CONFIGure:ARRay:CHECK or MEASure:ARRay:CHECK? command sent (only one test result is stored if the last CONFIGure or MEASure command sent was of SCALAR type). Note that while the test state is on, the measurement buffer is constantly updated with new test results.

The value of the test results is a count of pulses, the absolute value of which is relatively unimportant. However, the results obtained must be stable.

Reception of this command turns off all other states in the TEST subtree.

Initialization:

*RST OFF

Example:

"TEST2:TEC:LONG ON"

Tests stop TEC circuit using a long calibrate pulse.

Interrogative form:

TEST2:TEC:LONG[:STATe] ==> <ON | OFF>

Returns the current state of the test.

TEST[1 | 2]:DAC[:STATe]

<OFF | ON>

Description:

This command checks the functionality of the DACs (Digital to Analog Converter) with a ramp trigger. Note that it is only active when the CHECK function is selected.

Since this test checks both DACs, the channel number is irrelevant.

On reception of this command, the 2461 TYPE C checks the operation of the DACs continuously until the state is turned off, another state is turned on, or the CHECK function is de-selected.

Reception of this command turns off all other states in the TEST subtree.

Initialization:

*RST OFF

Example:

"TEST:DAC ON"
Tests the DACs.

Interrogative form:

TEST[1 | 2]:DAC[:STATe] ==> <ON | OFF>

Returns the current state of the DACs test.

TRIGGER SUBSYSTEM

The TRIGger subsystem is made up of a series of commands to configure the arming layer of the trigger model.

The trigger model for the 2461 TYPE C is based on the expanded capability Trigger Model with subservient sequences defined in the SCPI Command reference.

Changing any of the ARMing settings invalidates the previously acquired data.

Below is the diagram for the 2461 TYPE C trigger subsystem:

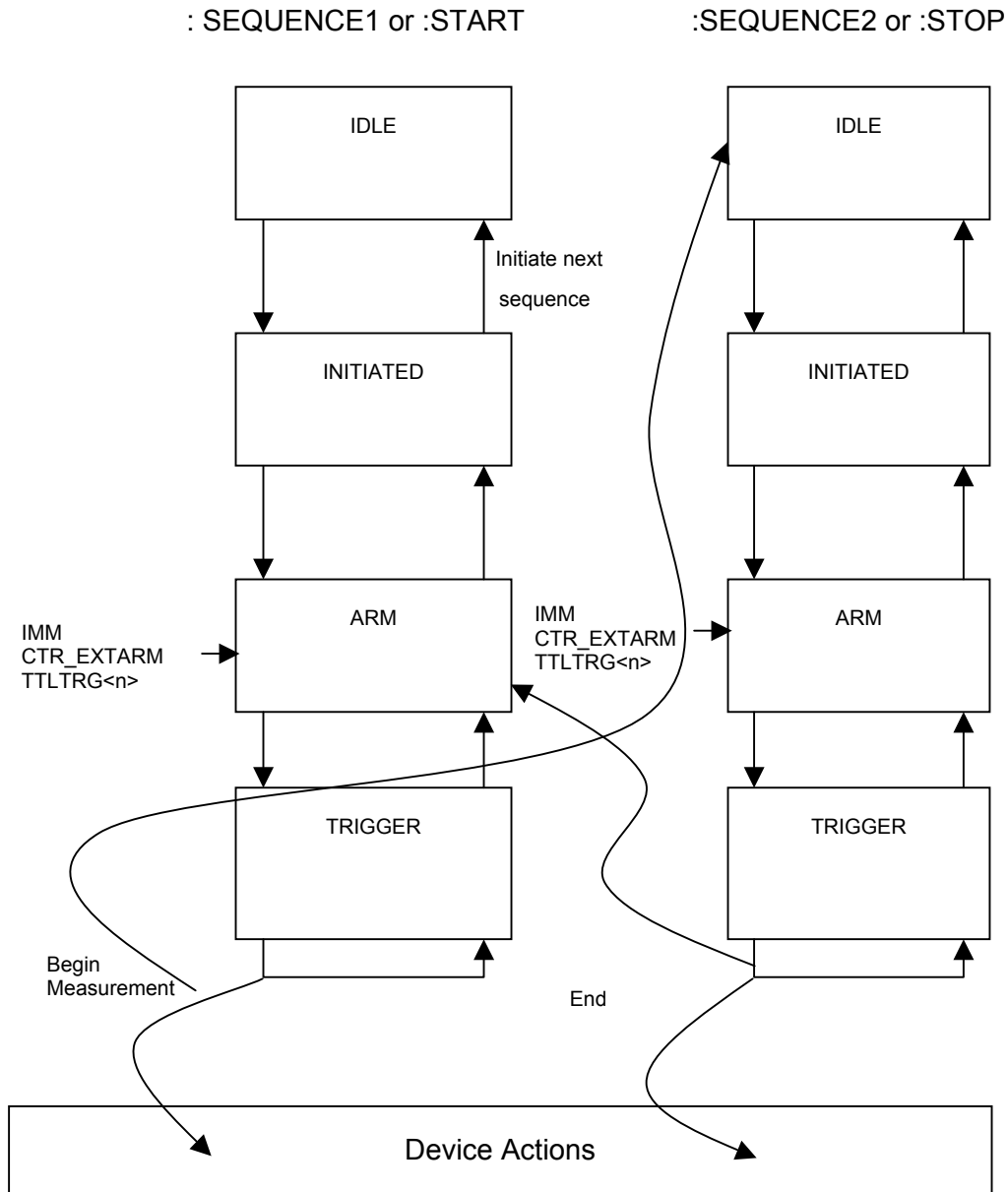

The diagram above is based on the expanded capability Trigger Model with subservient sequences.

SEQUENCE2 above is subservient to SEQUENCE1. The series of action are:

The Trigger model Start sequence moves into the initiate state on the command INIT:IMM or INIT:CONT ON. SEQUENCE1 or the START sequence will then move through the Initiated state and either proceed straight to the trigger layer, if the command ARM:START:SOUR IMM (default) has been set or wait for the arm event, set by ARM:START:SOURCe CTR_EXTARM | TTLTRG<n>. Once this event has occurred then SEQUENCE1 proceeds to the Trigger state.

Once in the Trigger state, SEQUENCE1 will now wait for the trigger conditions to be satisfied, set by INPUT[1|2]:COMP:LEVEL and INPUT[1|2]:COMP:SLOPE commands, and then the device action 'Begin Measurement' happens. SEQUENCE1 then moves back up through the Trigger layer to the Arm layer but is prevented from going further by the need of an event, the device action 'End Measurement'.

The device action 'Begin Measurement' now moves the SEQUENCE2, or STOP sequence, through the initiated state and straight to the arm state, and either proceed straight to the trigger layer, if the command ARM:STOP:SOUR IMM(default) has been set or wait for the arm event, set by ARM:STOP:SOURce CTR_EXTARM | TTLTrg<n>. Once this event has occurred then Sequence2 proceeds to the Trigger state.

Once in the Trigger state, Sequence2 will now wait for the trigger conditions to be satisfied, set by INPut[1|2]:COMP:LEVEL and INPut[1|2]:COMP:SLOPe commands, and then the device action 'End Measurement' happens. Sequence1 then moves back up through the Trigger layer all the way to the Idle layer. The device action, 'End Measurement' causes an event occurrence which allows SEQUENCE1 to proceed to check the measurement count.

SEQUENCE1 now will either move to the down path at the start of the Arm layer(measurement count not yet complete) or move up to the Initiate layer(Measurement count complete). In the Initiated layer, the command INIT:CONT ON is checked and, if received, moves to the down path and encounters the Arm layer once again. If INIT:CONT ON is not received then SEQUENCE1 moves up to the IDLE layer and waits for the next command.

TRIGger command summary

COMMAND	DESCRIPTION
INITiate	Enter in the INITiate state.
:IMMediate	
:CONTInous	Causes the 2461 TYPE C to operate in continuous mode
[:STATe]	
ABORt	Aborts and operation in progress
ARMing	
([:SEQuence1] :START)[:LAYer]	
:SLOPe	Slope of the arming signal for start.
:SOURce	Source of the arming signal for start.
:(SEQuence2 STOP) [:LAYer]	
:SLOPe	Slope of the arming signal for stop.
:SOURce	Source of the arming signal for stop.

INITiate[:IMMediate]**Description:**

The INITiate:IMMediate command causes the trigger system to initiate and complete one full trigger cycle, returning to the Idle state on completion.

If the device is not in the Idle state an IMMediate command has no effect on the trigger system and an error –213 is generated (“Init ignored”).

Initialization:

Trigger system in idle state.

Example:

```
"INITiate:IMMediate"
```

Initiates a single measurement.

Initialization:

N/A

Example:

"ABORt"

Stops immediately the instrument activity in progress and places the instrument in the Idle state.

**ARMing([:SEQuence1] | :STARt)[:LAYer]:SLOPe
<POSitive| NEGative | DEFault>**

Description:

Selects the slope of the start arming signal. If the currently selected source for the start arming is IMMEDIATE, then this command has no immediate effect.

If the device is not in the Idle state, this command has no effect on the trigger system and an error -221 is generated ("Setting conflict").

Initialization:

*RST POS

Example:

"ARMing:STARt:SLOPe POS"

Selects a positive slope for the start arming.

Interrogative form:

ARMing:([SEQuence1] | STARt)[:LAYer]:SLOPe?
==> <POSitive | NEGative>

Returns the slope of the start arming signal.

**ARMing([:SEQuence1] | :STARt)[:LAYer]:SOURce
<CTR_EXTARM | TTLTrg<0..7> | IMMEDIATE >**

Description:

Selects the start arming source to be used when the 2461 TYPE C is initiated.

When <CTR_EXTARM> is specified, then if the current source for the stop arming is TTLTrg, this will be forced to CTR_EXTARM.

When <TTLTrg> is specified, then if the current source for the stop arming is CTR_EXTARM, this will be forced to TTLTrg.

If the TTLTrg line specified is already being used for the gate output signal of one of the 2461 TYPE C boards in the system (refer to the OUTPUT subsystem), then the error -221 is generated ("Setting conflict").

If the device is not in the Idle state this command has no effect on the trigger system and an error -221 is generated ("Setting conflict").

Initialization:

*RST IMMediate

Example:

"ARMIing:STARt:SOURce TTLTrg5"

 Selects a TTL trigger line 5 for the start arming.

Interrogative form:

ARMIing ([:SEQuence1] | :STARt)[:LAYer]:SOURce?
==> <CTR_EXTARM | TTLTrg<0..7> | IMMediate >

 Returns the source of the start arming signal.

**ARMIing:(SEQuence2 | STOP) [:LAYer]:SLOPe
<POSitive | NEGative | DEFault>**

Description:

Selects the slope of the stop arming signal. If the currently selected source for the stop arming is IMMEDIATE, then this command has no immediate effect.

If the device is not in the Idle state, this command has no effect on the trigger system and an error –221 is generated (“Setting conflict”).

Initialization

N/A

Example:

```
"ARMIing:STOP:SLOPe POS"
```

Selects a positive slope for the stop arming.

Interrogative form:

```
ARMIing:(SEQuence2 | STOP)[:LAYer]:SLOPe? ==>
<POSitive | NEGative >
```

Returns the slope of the stop arming signal.

```
ARMIing: (SEQuence2 | STOP) [:LAYer]:SOURce
<CTR_EXTARM | TTLTrg<0..7> | IMMEDIATE>
```

Description:

Selects the start arming source to be used when the 2461 TYPE C is initiated.

When <CTR_EXTARM> is specified, then if the current source for the start arming is TTLTrg, this will be forced to CTR_EXTARM.

When <TTLTrg> is specified, then if the current source for the start arming is CTR_EXTARM, this will be forced to TTLTrg.

If the TTLTrg line specified is already being used for the gate output signal of one of the 2461 TYPE C boards in the system (refer to the OUTPut subsystem), then the error –221 is generated (“Setting conflict”).

If the device is not in the Idle state this command has no effect on the trigger system and an error –213 is generated (“Init

ignored”).

Initialization:

*RST IMMEDIATE

Example:

“ARMing:STOP:SOURce TTLTrg2”

Selects a TTL trigger line 2 for the stop arming.

Interrogative form:

```
ARMing: (SEQUence2 | STOP)[:LAYer]:SOURce? ==>
                                <CTR_EXTARM |
                                TTLTrg<0..7> |
                                IMMEDIATE>
```

Returns the source of the stop arming signal.

**2461 TYPE C-
Specific Error
Messages**

Error Description [Description/Explanation/Examples]

Number

-311 Memory-related error

[An error has occurred in one of the memory areas of the module. The problem may arise when programming the Non-volatile memory or when transferring samples in DMA mode.]

-340 Calibration failed

[An error has occurred during the calibration process]

-350 Queue Overflow

[A specific code has been entered in the Queue instead of the code, which caused the error. This code indicates that the Queue is full and that the error that occurred has not been recorded.]

Examples Of SCPI Commands Used To Manipulate The Instrument

Selecting The Counter Function Card

Before any use can be made of the 2461 TYPE C function card it is necessary to select the card that the operator wishes to address. This is done by the SCPI command:

```
INST:SEL COUNTER1
```

If the counter is located in the top of the 2461 module.

To access another counter in the lower half of the module the command should be

```
INST:SEL COUNTER2
```

If the operator is uncertain what is in the 2461 then he can interrogate the unit by sending:

```
INST:CAT?
```

The reply may consist of up 3 fields separated by the comma character. The first field indicates what is in the upper position, the second field, if present, indicates what is in the lower position and the third field indicates what is mounted internally to the 2461. Note that if the second field is present but a null value then the lower position is unoccupied.

Note that the default setting is function card 1.

Preparation For Measurement

In general the user will prepare the 2461 TYPE C for measurement and then command the 2461 TYPE C to take that measurement.

The user should prepare for measurement first by using the SENSE subsystem to select the primary measurement function, measurement resolution, averaging state, etc.

The operator should now prepare the input conditioning by using the INPUT subsystem to select such parameters as coupling, impedance, hysteresis level, filtering, trigger slopes and level (or if trigger level should be determined automatically).

The operator should now prepare the arming source using the ARM subsystem.

Examples:

To measure the frequency on Input 1 of a 150MHz signal to 1Hz resolution using Auto trigger, and the 50Ω input using a reference plugged into the front panel, the following commands

should be sent:

*RST

This command should be used if the state of the instrument is unknown. This will return all settings to their default state. Now the commands should be sent:

```
SENS1:FUNC "FREQ"; SENS:RES 9; INP:IMP 50;  
COMP:SET:AUTO ON; SOUR:ROSC EXT
```

This concludes the preparation. Note that the short version of all mnemonics for commands was used

Another example

To measure the time interval from Input 2 to Input 1 of a sub 50 Hz TTL noisy signal and the 1M Ω input using the clock10 reference, the following command should be sent:

*RST

This command should be used if the state of the instrument is unknown. This will return all settings to their default state. Now these commands should be sent:

```
SENS2:FUNC "TINT"; SENS:RES 5; INP1:COUP DC;  
FILT:STATE ON; COMP:LEV:REL 1.8; INP2:COUP DC;  
FILT:STATE ON; COMP:LEV:REL 1.8
```

This concludes the preparation. Note that the short version of all mnemonics for commands was used.

Triggering And Retrieving

The SCPI standard provides 3 commands for retrieving and/or taking measurements and two commands for triggering measurements.

Measurements

BASICS

The two commands that trigger measurement cycles are: INIT:IMM and INIT:CONT ON

INIT:IMM starts one measurement cycle during which the 2461 TYPE C is in the INITIATE state. When the measurement cycle is complete, the instrument returns to the IDLE state.

INIT:CONT ON starts continuous measurements so that the 2461 stays in the initiate state.

When the instrument is in the initiate state, the only legal commands that can be accepted without error are ABORT, INIT:IMM, INIT:CONT OFF, READ? or MEAS?. These commands either return the instrument to the idle state or trigger one further measurement and then return to the idle state.

There are 3 query commands defined by SCPI for retrieving measurements and they are in hierarchical order.

The simplest command is the FETCH? command which causes the 2461 to place a previously taken measurement into its output buffer ready for the operator to read back the result.

The next command is the READ? command which triggers the 2461 and when the measurement is complete, places the result in the output buffer as before. The READ? command is equivalent to ABOR;INIT:IMM; FETCH?

The MEAS? command is the most complex command and allows re-configuration of the measurement function, triggers the instrument and, when the measurement is complete, places the result into the output queue. The command is equivalent to ABOR;CONF;INIT:IMM:READ?

The command MEAS:FREQ? causes the 2461 TYPE C to take one frequency measurement and return the result. If the command MEAS:PER? is now sent, the main function is changed to period, a reading is triggered and the result is returned. This command allows re-programming of the main measurement function, and optionally the number of readings, rapidly without changing any other conditions.

MULTIPLE MEASUREMENTS

It is possible to command the 2461 TYPE C to take multiple, or array, type measurements using the CONFigure subsystem. The CONF command is used standalone or with the MEAS? Command.

CONF1:ARR:FREQ 10

If the command CONF1:ARR:FREQ 10 is sent, then when the command INIT:IMM is sent, 10 frequency measurements on input 1 will be taken and the results placed in the output queue.

AUTOMATIC RESOLUTION

It is possible to have the 2461 TYPE C function card set the resolution automatically if the expected value and measurement resolution are supplied. This is done using the CONF command. If it is desired to measure 150MHz to 1Hz resolution then the command

CONF:FREQ 150E6, 1

will ensure that the correct resolution, or gate time, is adequate for the required resolution. To take 10 frequency measurements of the same frequency and resolution then send:

CONF:ARR:FREQ 10, 150E6, 1

If only two parameters are present then the first will be taken as the array size and the second ignored.

This page was left intentionally blank.

USING THE VXI *plug&play* INSTALL DISKS

Operating The VXI *plug&play* Install Disk

Use of the plug and play install disk allows the operator to develop programs without intimate knowledge of the command set, SCPI or IEEE 488.2 standards.

After obtaining the instrument handle, or handles if there is more than one 2461 in the system, the user follows the same basic procedure as under the OPERATION VIA THE SCPI COMMAND SET in that the user prepares the various subsystems for the type of measurement to be taken. Once this has been completed the user can now call functions to trigger and retrieve measurements. To access a particular function card the operator must always pass the card type variable to any function calls to the 2461 Type C function card of interest.

All retrieved information, that is numerical in nature, is converted into numerical types for easy manipulation by the user. Array type measurements are also returned as numeric arrays. Returned string data is also converted to numerical data for easy manipulation in the user program

Using The Soft Front Panel

The soft front panel allows the operator interactive control over the 2461 Type C function card to allow instrument operation. All major functions are provided.

To use the soft front panel the install disk must first be installed. The soft front panel application should be launched. The soft front panel application will now search for a 2461, or multiple 2461, in the VXI system. If a window appears with the message 'No 2461 found in Chassis. Do you want to run in Demo mode?' and it is desired to run the demonstration version, select the 'YES' option.

If one or more 2461 are found then the main front panel of the 2461 will appear on the screen and the operator should select the Universal Counter Timer. The main 2461 UCT panel will now appear and the title bar will contain the instrument slot number together with the Function Card number so the actual 2461 TYPE C that is being controlled can be identified. This panel is shown if Figure 5-1.

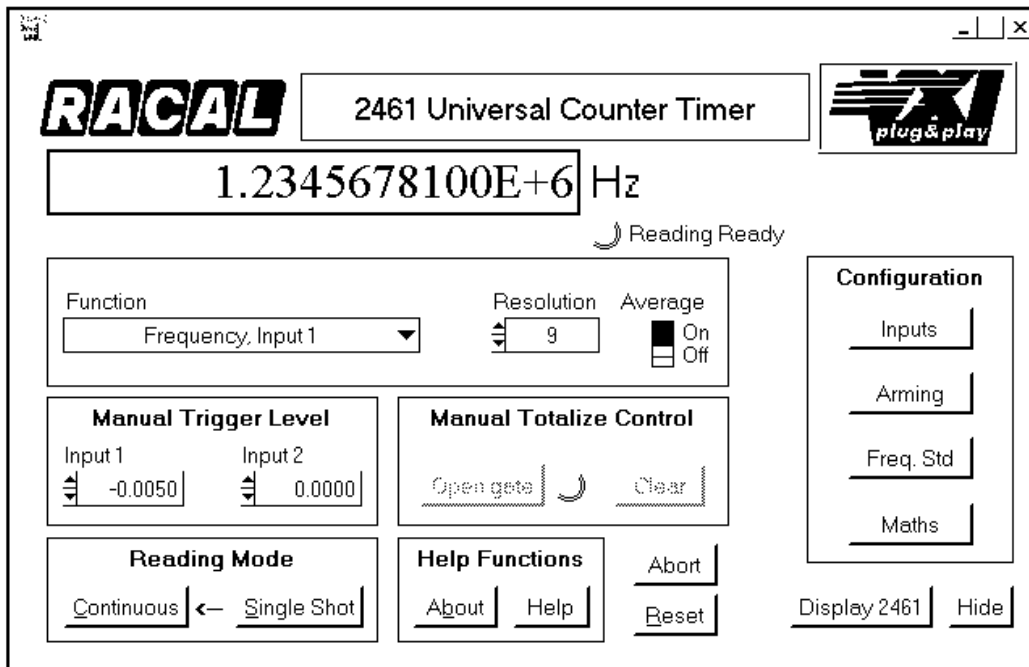

Figure 5-1, 2461-C Front Panel

The controls are:

The **Function** list box allows the user to select the 2461 TYPE C measurement function. The functions available are:

- "Frequency Input 1"
- "Frequency Input 2"
- "Frequency Input 3"
- "Period Input 1"
- "Period Input 2"
- "Time interval Input 1 to Input 2"
- "Time interval Input 2 to Input 1"
- "Total Input 1 by Input 2"
- "Total Input 2 by Input 1"
- "Manual Total Input 1"
- "Manual Total Input 2"
- "Ratio Input 1/Input 2"
- "Ratio Input 3/Input 2"
- "Check"
- "Phase of Input 1 relative to Input 2"
- "Phase of Input 2 relative to Input 1"
- "Risetime"
- "Falltime"

"Positive pulse width"
"Negative pulse width"
"Volts middle, Input 1"
"Volts middle, Input 2"
"Volts maximum, Input 1"
"Volts maximum, Input 2"
"Volts minimum, Input 1"
"Volts minimum, Input 2"

The **Resolution** text box controls the number of digits of resolution of measurement results.

The **Average** binary switch enables or disables the averaging of measurement results. When Average is enabled, the 2461 Type C takes 100 measurements and calculates the average value.

The **Input1** and **Input2** text boxes in the Manual Trigger Level group control the trigger levels of the two channels when Manual Trigger is set. Note that updating these levels while in Auto Trigger mode automatically enables Manual Trigger mode.

The **Open Gate** and **Clear** controls manage the Manual Totalize function. The Open Gate command button is used to start and stop the counting. Successive counts are cumulative. The Clear button allows the user to reset the Totalize count.

The **Single Shot** and **Continuous** buttons control the actual measurement process. Pressing the Single Shot button initiates a 2461 Type C measurement and acquires the result. Pressing the Continuous button causes the 2461 Type C to take continuous measurements with the results reported in real-time.

The **Abort** button aborts the measurement in progress by forcing the 2461 Type C into the Idle State.

The **RESET** button resets only the currently selected UCT if there are two UCT's installed.

The **Help** button supports on-line help that provides the user with an efficient way to use the panel without referring to printed documentation.

The **Arming** button (Configuration group) manages the source and slope selection of the arming circuits. These settings are contained in the secondary panel illustrated in figure 5-2.

The **Inputs** button (Configuration group) displays the secondary panel illustrated in figure 5-3 and allows the user to specify some 2461 Type C input characteristics, such as attenuation, coupling, impedance, etc.

The **Frequency Standard** button (Configuration group)

displays the secondary panel illustrated in figure 5-4 and enables the user to choose the clock reference.

The **Maths** button (Configuration group) manages the mathematical functionality supported by the 2461 Type C. The associated secondary panel, shown in figure 5-5, allows the user to enable or disable the math processing and specify Scale and Offset values.

The **About** button, shown in figure 5-6, contains information on the instrument *Install Disk*.

The **Display 2461** button re-enables the main Soft Front Panel of the 2461 application.

The **Hide** button temporarily disables the panel 2461 Type C panel.

Arm Source Configuration

The *Start Arm Source* and *Stop Arm Source* controls have the following entries:

- “Internal”
- “External, Positive Slope”
- “External, Negative Slope”

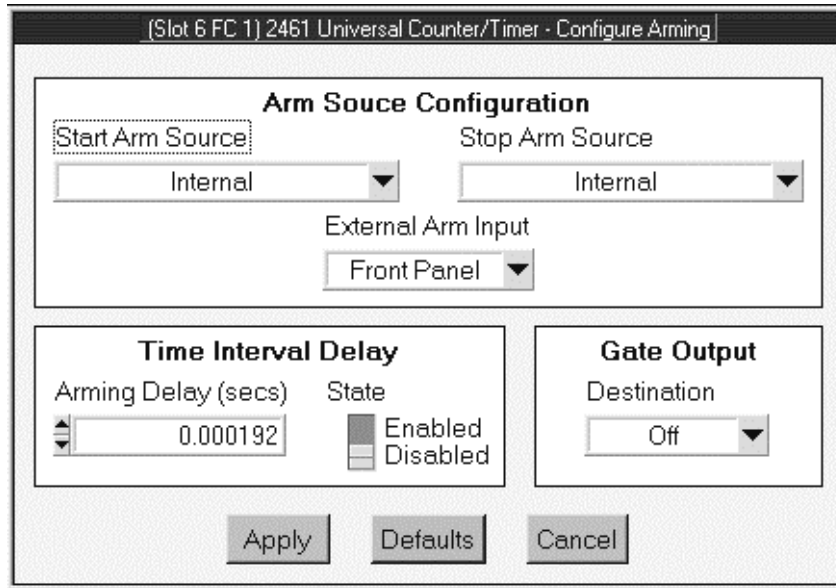

Figure 5-2, Configure Arming secondary panel

The “External Arm Input” control specifies the source of the external arming and has the following entries:

- “TTLTRG0”
- “TTLTRG1”
- “TTLTRG2”
- “TTLTRG3”
- “TTLTRG4”
- “TTLTRG5”
- “TTLTRG6”
- “TTLTRG7”
- “Front Panel”

The Gate Output *Destination* control has the following entries:

- “TTLTRG0”
- “TTLTRG1”
- “TTLTRG2”
- “TTLTRG3”

“TTLTRG4”

“TTLTRG5”

“TTLTRG6”

“TTLTRG7”

“Off”

Configure Inputs

For each 2461 Type C function card, the following parameters can be set:

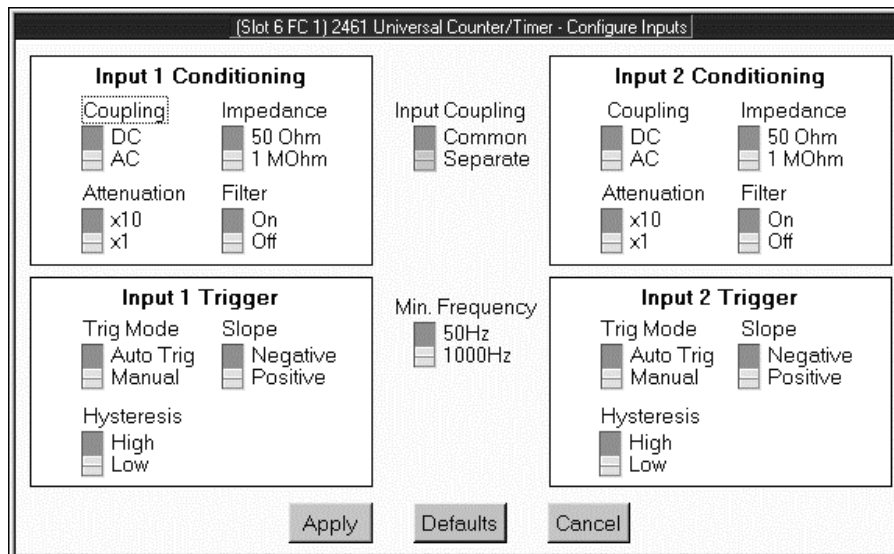

Figure 5-3, Configure Input secondary panel

- The **Coupling** control sets the input coupling (AC or DC).
- The **Impedance** control sets the terminating impedance (50Ω or 1MΩ).
- The **Attenuation** control sets the input block signal attenuator (x1 or x10).
- The **Filter** control enables or disables the input low-pass filter.
- The **Trigger Mode** control selects either Auto Trigger or Manual Trigger.
- The **Slope** control sets the trigger slope, which can be either positive or negative.
- The **Hysteresis** control selects the input hysteresis voltage (high or low).

The ***Input Coupling*** and ***Minimum Frequency*** are common settings that apply to both channels.

The Input Coupling control connects or separates input channel 1 and 2. If Common is set, the signal at channel 1 is connected to both channels.

The Minimum Frequency control sets the minimum frequency of the auto trigger algorithm. This can be 50Hz or 1000Hz.

The ***Apply*** command button invokes the changes to the settings. The ***Default*** command button initializes the controls to the power-up settings, but does not invoke the changes unless ***Apply*** is subsequently operated. The ***Cancel*** button closes the soft front panel ignoring any change made to the settings.

Select Reference

The **Frequency Standard** control sets the standard reference. This can be derived from the VXI backplane (Clock10), or be either an optional Internal Standard or an External reference. Note that if no internal standard is installed this will not be offered as a choice.

The **Apply** command button invokes the change to the frequency standard setting. The **Cancel** button closes the panel leaving the frequency standard setting unchanged.

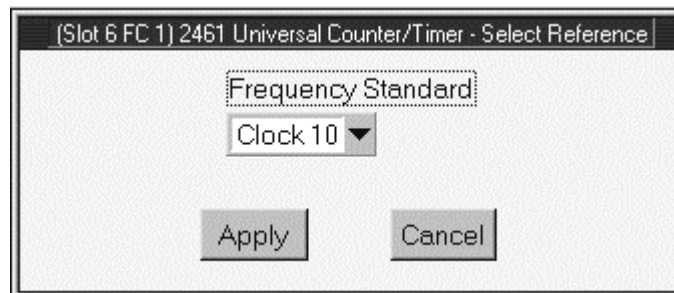

Figure 5-4, Select Reference

Configure Math Function

The **Enable** control enables or disables the math processing. The **Offset** and **Scale** parameters can either be the last measurement or a numerical value to be specified in the input box. Note that the last measurement cannot be used as offset and scale parameter at the same time.

The **Apply** command button invokes the changes to the settings. The **Default** command button initializes the settings to the power-up state. The **Cancel** button closes the soft front panel ignoring any change made to the settings.

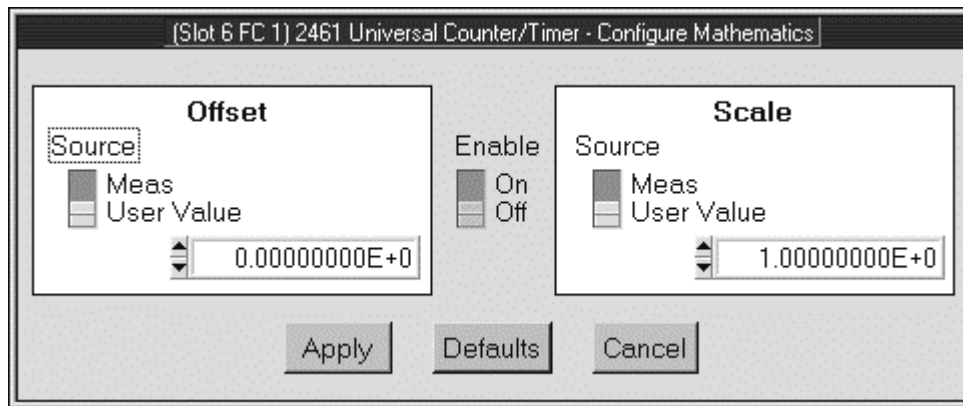

Figure 5-5, Configure Math Function secondary panel

About

This secondary panel shows the Software Revisions (both Soft Front Panel and Instrument *Install Disk*) and details of the instrument, such as name, SCPI version, firmware revision and the module serial number.

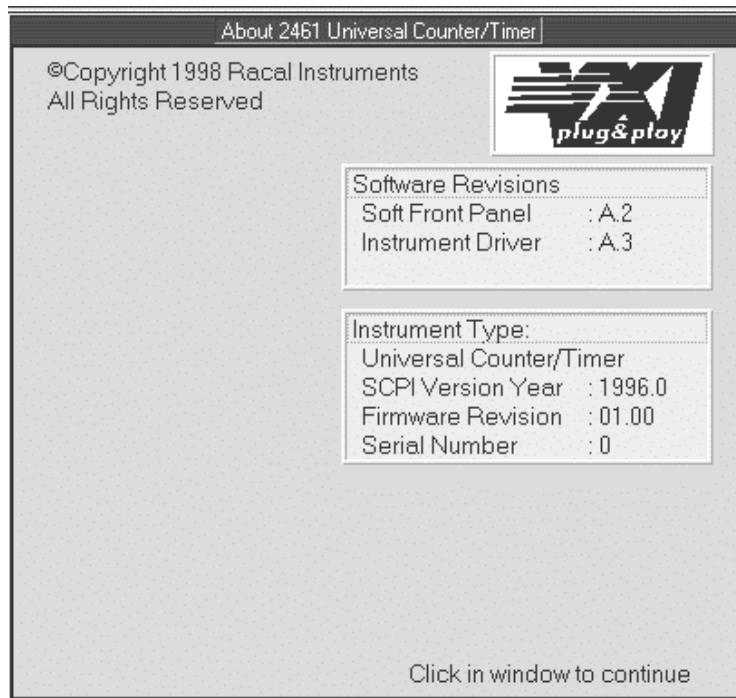

Figure 5-6, About secondary panel

PERFORMANCE VERIFICATION AND ADJUSTMENTS

Introduction

This Chapter describes the procedures for checking that the UCT Instrument conforms to its published specifications when fitted to a Racal 2460 VXI Instrument module. It is recommended that these procedures are carried out at a minimum interval of one year.

The following conditions must be kept throughout the Performance Verification Procedure (PVP).

- (1) The instrument covers must be fitted.
- (2) The ambient temperature must be $23^{\circ}\text{C} \pm 2^{\circ}\text{C}$.
- (3) The UCT must be allowed to warm up for a least one hour before commencing the PVP.

In the following procedures, a stable count is defined as one that does not vary by more than \pm one count in the least significant digit of resolution between successive readings.

Note that these procedures check the measurement circuitry of the UCT but not the absolute accuracy. Absolute accuracies must be calculated from the expressions given in the Specifications section of this manual after finding the timebase errors that apply to the external frequency standard or CLK10 signals used by the UCT.

Test Equipment Required

- (1) Signal Generator, 10kHz to 1.3GHz
- (2) Function Generator, DC to 10kHz
- (3) DC Voltage Calibrator
- (4) Digital Multimeter, \pm 5% Accuracy, DC to 100kHz
- (5) RF Millivoltmeter,
- (6) Various RF connectors, adapters, T-pieces and coaxial cables, as required.

Note: In the following procedures, it is recommended that all signal levels are measured with the Digital Multimeter or RF Millivoltmeter, as appropriate, and adjusted to give a level as close to its nominal value as can be achieved before being applied to the UCT.

Input 1 Sensitivity Test

Set the UCT to its default state. Select 50Ω input impedance for input 1, and select external frequency standard.

Equipment: Signal Generator

Configure UCT as follows:

*RST	returns unit to default state
INP1:IMP 50	selects 50Ω impedance
selects external frequency	standard

If the UCT is fitted with a TCXO or OCXO oscillator option, connect the UCT internal reference output to the external signal source 10MHz Input. Configure the external signal source to accept the 10MHz reference from the UCT.

Connect the Function Generator to the UCT as shown in Figure 6-1.

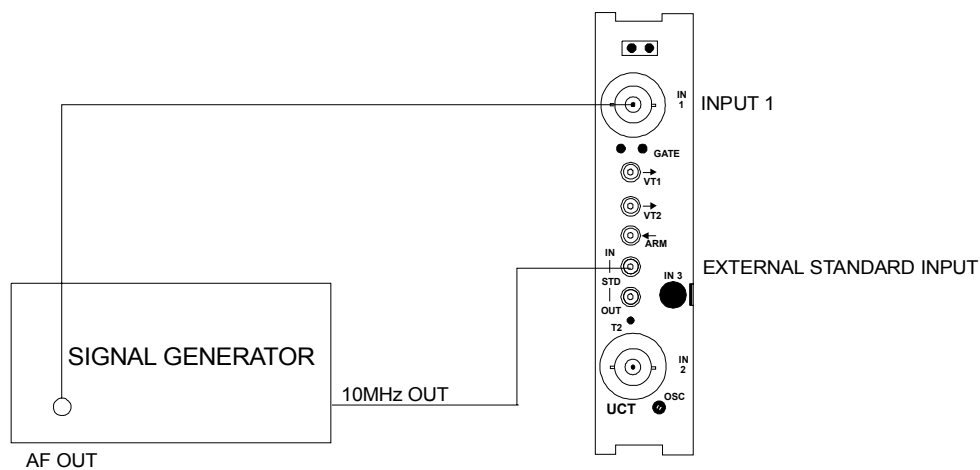

Figure 6-1, Input 1 Low Frequency Sensitivity Test Configuration

Apply the frequencies, amplitudes and resolution settings given in the following table to the UCT. Check that the UCT gives a stable reading within the tolerances given, at less than the signal levels given (example: a stable reading at 20mV instead of the listed 25mV).

Command Syntax:

MEAS1:FREQ?	takes a frequency measurement
-------------	-------------------------------

Table 6-1, Input 1 Sensitivity Low Frequency Test

Frequency	Signal level	Resolution Command Syntax	Tolerance
10Hz	25mV rms	SENS:RES 8	± 1Hz
5kHz	25mV rms	SENS:RES 8	± 0.1Hz
10kHz	25mV rms	SENS:RES 8	± 0.1Hz

Set the UCT measurement resolution to the values given in the following table and apply the Frequencies given to the UCT input 1. Check that the UCT gives a stable reading within the tolerances given, at less than the signal levels given.

Table 6-2, Input 1 Sensitivity high Frequency Performance Limits

Frequency	Signal level	Resolution Command Syntax	Tolerance
200MHz	50mV rms	SENS:RES 9	± 1Hz
160MHz	50mV rms	SENS:RES 9	± 1Hz
100kHz	50mV rms	SENS:RES 9	± 1Hz
10MHz	25mV rms	SENS:RES 8	± 1Hz
100kHz	25mV rms	SENS:RES 8	± 0.1Hz

Disconnect the test equipment.

Input 2 Sensitivity Test

Set the UCT to its default state. Select 50Ω input impedance for input 2, and select external frequency standard.

Equipment: Signal Generator

Configure UCT as follows:

*RST	returns unit to default state
INP1:IMP 50	selects 50Ω impedance
selects external frequency standard	

If the UCT is fitted with a TCXO or OCXO oscillator option, connect the UCT internal reference output to the external signal source 10MHz Input. Configure the external signal source to accept the 10MHz reference from the UCT.

Connect the Function Generator to the UCT as shown in Figure 6-2.

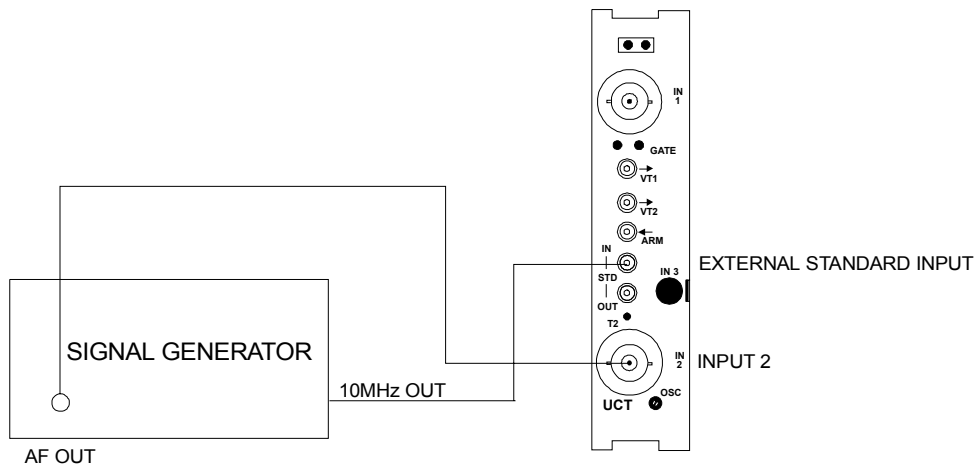

Figure 6-2, Input 2 Low Frequency Sensitivity Test Configuration

Apply the frequencies given in the following table to the UCT. Check the UCT gives a stable reading within the tolerances given, at less than the signal levels given.

Command Syntax:

MEAS1:FREQ?	takes a frequency measurement
-------------	-------------------------------

Table 6-3, Input 2 Sensitivity Low Frequency Tests

Frequency	Signal level	Resolution Command Syntax	Tolerance
10Hz	25mV rms	SENS:RES 8	± 1Hz
5kHz	25mV rms	SENS:RES 8	± 0.1Hz
10kHz	25mV rms	SENS:RES 8	± 0.1Hz

Set the UCT measurement resolution to the values given in the following table and apply the Frequencies given to the UCT input 2. Check that the UCT gives a stable reading within the tolerances given, at less than the signal levels given.

Table 6-4, Input 2 Sensitivity High Frequency Tests

Frequency	Signal level	Resolution Command Syntax	Tolerance
100MHz	50mV rms	SENS:RES 9	± 1Hz
100kHz	50mV rms	SENS:RES 9	± 1Hz
10MHz	25mV rms	SENS:RES 8	± 1Hz
100kHz	25mV rms	SENS:RES 8	± 0.1Hz

Disconnect the test equipment.

Input 3 Performance Verification

Note:

This procedure must be carried out with the prescaler already fitted into the host 2461.

Perform the following steps:

1. Interconnect the 2461 (UUT) and signal generator as shown:

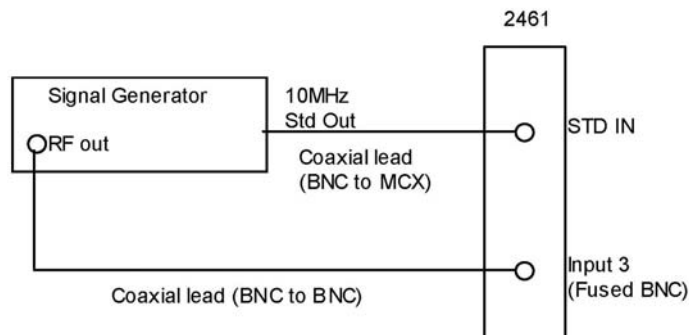

2. Set R27 on assembly 19-1142 fully clockwise
3. Switch on the VXIbus mainframe.
4. If required run the resource manager.
5. Start the setup program “RI2461Chan3Setup.exe” (Racal Instruments Limited, p/n 60-0165)
(Be aware that this program sets the “Input 3 Hardware Fitted” bit in the non-vol memory of the 2461, and should NOT, therefore, be run with a 2461 that is not fitted with this hardware.)
6. If there is more than one 2461 in system select the required 2461, otherwise selection is automatic.
7. If the 9087 is connected via the GPIB then it will be controlled automatically, otherwise set the signal generator output to 1GHz at 10.0mV rms (i.e. follow the instructions as presented by the program.)
8. Adjust R27 counter-clockwise until the measured reading just starts displaying 1000000000 ± 1 (Turn R27 very slowly to prevent over-shooting the correct adjustment.)
9. When ready, press “Check Inhibit”
10. Again, if the 9087 is connected via the GPIB then it will be controlled automatically, otherwise set the signal generator output to 1GHz at 8.5mV rms (i.e. follow the

instructions as presented by the program.)

11. Verify that the 2461 is not counting. If it is, repeat steps 7 to 12, (i.e. follow the instructions as presented by the program.)
12. When satisfied that the setup is complete press “Stop” followed by “Close”
13. Switch off the VXIbus mainframe. Disconnect the test equipment.

Alternatively, if the setup program is not available, use the following procedure:

1. Follow steps 1 to 4 above
2. Using an appropriate VISA interactive control program send the following commands to the 2461C:
 - “CAL:STAT ON”
 - “CAL:DATA? NVM,25” and read back the response
Bitwise “OR” this value with 4 to produce “new value” (for example use the calculator within WIN NT, WIN95, etc)
 - “CAL:DATA NVM,25,<new value>”
 - “CAL:STAT OFF”

This will have set the “Channel 3 Fitted” flag in the non-vol memory of the UCT.

3. Start the 2461 soft front panel application program (Racal Instruments Limited, p/n 60-0084 and 60-0087) and select the UCT.
4. Select “Frequency, Input 3”
5. Select “Configure > Reference > Frequency Standard”; choose “External” and press “Apply” then “Hide”.
6. Select “Continuous” measurement mode.
7. Set the signal generator output to 1GHz at 10.0mv rms
8. Adjust R27 counter-clockwise until the measured reading just starts displaying $1.0000000000E+9 \pm 0.000000001$ (Turn R27 very slowly to prevent over-shooting the correct adjustment.)
9. Switch off the RF output of the signal generator and reduce the output level to 8.5mV rms
10. Switch on the RF output of the signal generator and verify that the 2461C is not counting, i.e. displays $99.0000000000E+36$. If it is still counting repeat steps 7 to 10.
11. Switch off the VXIbus mainframe

Time Interval 1:2 Test

Set the UCT to its default state. Select Time Interval 1:2 as the measurement mode, 50Ω impedance for input 1, Common mode for inputs 1 and 2 and External frequency standard.

Equipment: Signal Generator

Configure the UCT as follows:

*RST	returns unit to default state.
INP1:IMP 50	selects 50Ω impedance
IMP1:ROUT COMM	commons Channels1 and 2
selects external frequency	standard
CONF1:TINT	selects time Interval 1-2

If the UCT is fitted with a TCXO or OCXO oscillator option, connect the UCT internal reference output to the external signal source 10MHz Input. Configure the external signal source to accept the 10MHz reference from the UCT.

Connect the Function Generator to the UCT as shown in Figure 6-3.

Figure 6-3, Time Interval 1-2 Test Configuration

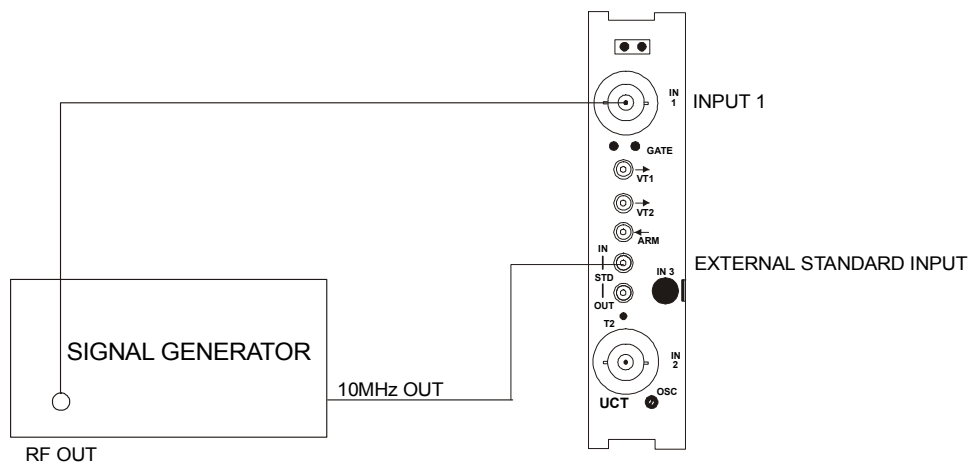

Set the UCT input trigger slopes as shown in the following table and check that the UCT measurement results are as given in Table 6-5.

Table 6-5, Time Interval 1-2 Test Performance Limits

Input 1 Slope Command Syntax	Input 2 Slope Command Syntax	Results	Tolerance
INP1:COMP:SLOP POS	INP2:COMP:SLOP POS	0ns	± 2ns
INP1:COMP:SLOP NEG	INP2:COMP:SLOP POS	50ns	± 2ns
INP1:COMP:SLOP NEG	INP2:COMP:SLOP NEG	0ns	± 2ns
INP1:COMP:SLOP POS	INP2:COMP:SLOP NEG	50ns	± 2ns

Command Syntax:

MEAS:TINT? takes a Time Interval measurement

Disconnect the test equipment.

Totalize 1 by 2 Test

Set the UCT to its default state. Select Totalize 1 by 2 as the measurement mode, 50Ω input 1 impedance, and external frequency standard.

Equipment: Signal Generator

Configure UCT as follows:

*RST	return unit to default state
INP1:IMP 50	selects 50Ω impedance for Input 1
SOUR:ROSC:SOUR EXT	selects external frequency standard

If the UCT is fitted with a TCXO or OCXO oscillator option, connect the UCT internal reference output to the external signal source 10MHz Input. Configure the external signal source to accept the 10MHz reference from the UCT.

Connect the UCT to the signal generator as shown in Figure 6-6. Set the signal generator to 10MHz, 0dBm. Check that the UCT measurement result is 5000 +/- 1.

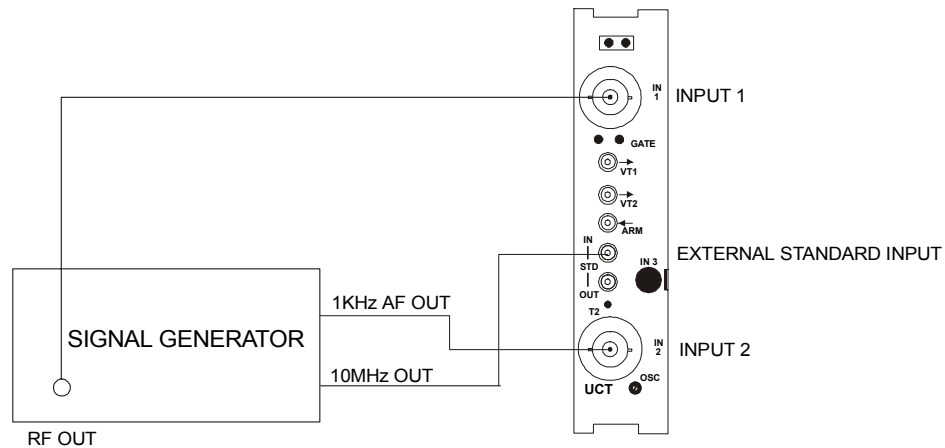

Figure 6-4, Totalize 1 by 2 Test Configuration

Command Syntax for making a Totalize measurement:

CONF1:TOT	configures UCT for Totalize measurement
MEAS1:TOT?	takes a totalize measurement

Ratio 1:2 Test

Set the UCT to its default state. Select Ratio 1:2 as the measurement mode, 50Ω for input 1 impedance, DC coupling for input 2, external frequency standard, and set the measurement resolution to three digits.

Equipment: Signal Generator

Configure UCT as follows:

*RST	returns UCT to default state
INP1:IMP 50	selects 50Ω impedance for Input 1
INP2:COUP DC	selects DC coupling for Input 2

Connect the signal generator's RF and LF outputs to the UCT's Inputs 1 and 2 as shown in Figure 6-5. Set the signal generator to 50MHz, 100mV rms. Check that the UCT measurement result is 50000 +/- 10.

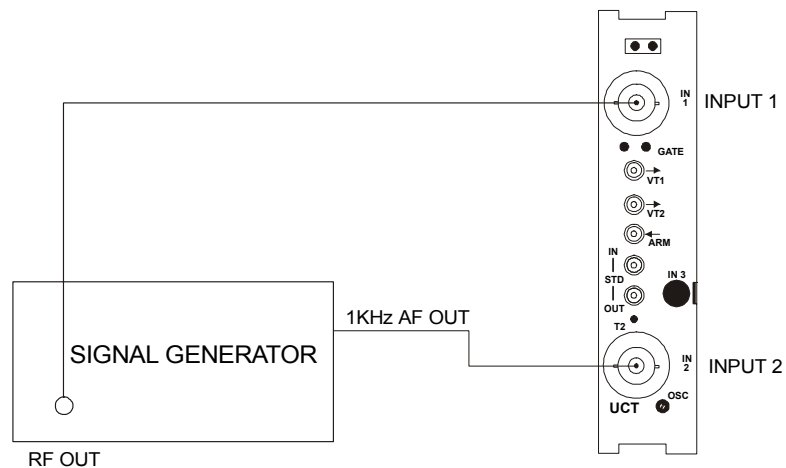

Figure 6-5, Ratio 1 : 2 Test Configuration

Command Syntax:

MEAS1:FREQ:RAT? measures the ratio of frequencies at
Inputs 1 & 2

Disconnect the test equipment.

Trigger Level Accuracy Test

Set the UCT to its default state. Set the UCT to DC coupling for Input 1.

Equipment: Dc Standard

Configure the UCT as follow:

*RST	returns UCT to default state
INP1:COUP DC	selects DC coupling for Input 1
INP1:COMP:SET:AUTO ON	turns Auto Trigger on

Connect the UCT to the DC standard as shown in Figure 6-6. Set the DC Standard output voltage to 1.000 volts. Next, change the DC standard output to 4,000 volts (this insures counter in x1 mode).

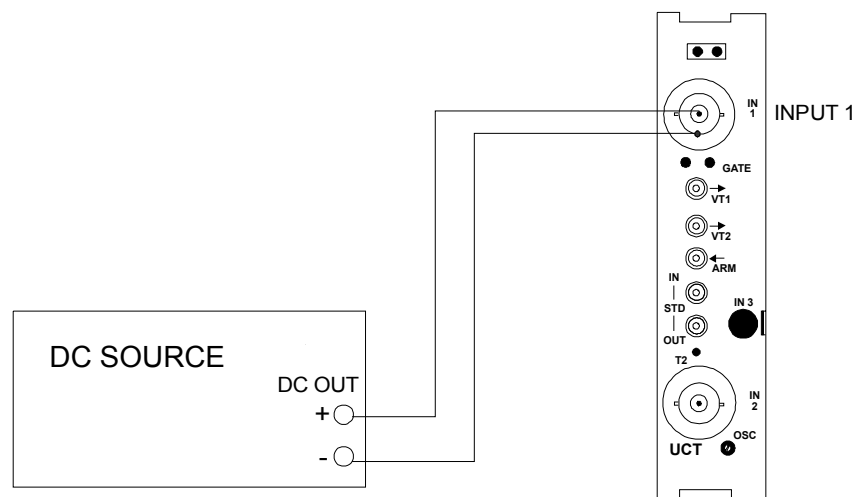

Figure 6-6 Input 1 Trigger Level Test Configuration

Connect the DC Standard to Input 1 of the UCT. Use following command syntax to verify that the trigger level is 4.000V +/- 290mV.

Command Syntax:

MEAS1:VOLT:MAX?	measures positive peak
-----------------	------------------------

Verify that the reading is 4.000V +/- 290mV.

Reverse the polarity of the DC input to UCT. Verify that the trigger level is -4.000V +/- 290mV.

Command Syntax:

MEAS1:VOLT:MIN? measures negative peak

Verify that the reading is -4.000V +/- 70mV.

Next, set the DC Standard output voltage to 8.000 volts. Use following command syntax to verify that the trigger level is 8.000V +/- 1.3mV.

Command Syntax:

INP1:COMP:SET:AUTO ON turns Auto Trigger on
 MEAS1:VOLT:MAX? measures positive peak

Verify that the reading is 8.000V +/- 1.3mV.

Reverse the polarity of the DC input to UCT. Verify that the trigger level is -8.000V +/- 380mV.

Command Syntax:

MEAS1:VOLT:MIN? measures negative peak

Verify that the reading is -8.000V +/- 1.3mV.

Disconnect the DC Standard from Input 1 and connect to Input 2. Configure the UCT for DC coupling on Input 2.

Repeat the same test for channel 2, connecting the DC source to channel 2 of the counter. The command syntax for the channel 2 test is as follows.

Disconnect the test equipment.

Test Voltage	Command Syntax	Tolerance
+4.000 V	INP2:COUP DC INP2:COMP:SET:AUTO ON MEAS2:VOLT:MAX?	290 mV
-4.000 V	MEAS2:VOLT:MIN?	290 mV
+8.000 V	MEAS2:VOLT:MAX?	1.3 V
-8.000 V	MEAS2:VOLT:MIN?	1.3 V

Functional Checks

Input 1 Filter Check

Set the UCT to its default state. Select 50 Ω impedance for Input 1.

Configure the UCT as follows:

*RST	returns unit to default state
INP1:IMP 50	selects 50 Ω impedance for Input 1

Connect the UCT to the signal generator as shown in Figure 6-7.

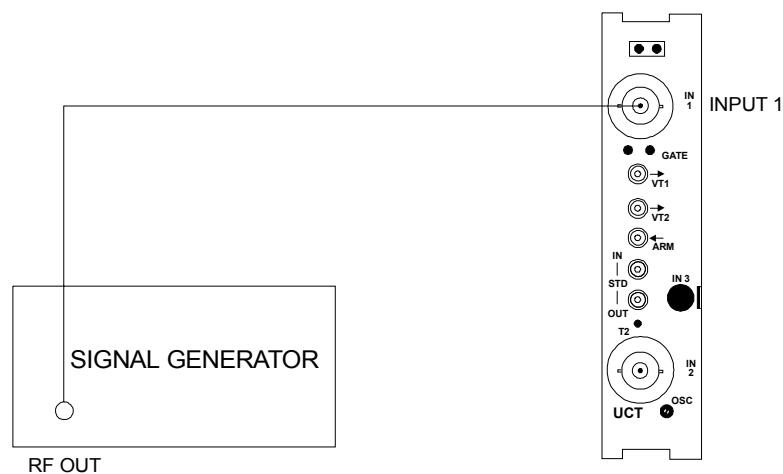

Figure 6-7, Input 1 Filter Check Configuration

Set the generator to 50kHz, 1Vrms. Check that the UCT is measuring 50kHz and the peak to peak signal level is:

Command Syntax	Notes
MEAS1:FREQ?	Confirm 50kHz
MEAS1:VOLT:MAX?	V_{P1}
MEAS1:VOLT:MIN?	V_{N1}

Switch in the input filter for channel 1 and again check that the counter measures a frequency of 50kHz. Measure the peak to peak signal and verify that the signal amplitude is reduced by greater than 2dB.

INP1:FILT:LPAS:STAT ON	turn on LPF for channel 1
MEAS1:FREQ?	Confirm 50kHz
MEAS1:VOLT:MAX?	V_{P2}
MEAS1:VOLT:MIN?	V_{N2}

Use the equation :

$$20 * \log((V_{P1} - V_{N1}) / (V_{P2} - V_{N2})) > 2.0$$

or

$$((V_{P1} - V_{N1}) / (V_{P2} - V_{N2})) > 1.25$$

to verify compliance.

Input 2 Filter Check

Set the UCT to its default state. Select 50Ω impedance for Input 2.

Configure the UCT as follows:

*RST	returns unit to default state
INP2:IMP 50	selects 50Ω impedance for Input 2

Connect the UCT to the signal generator as shown in Figure 6-8.

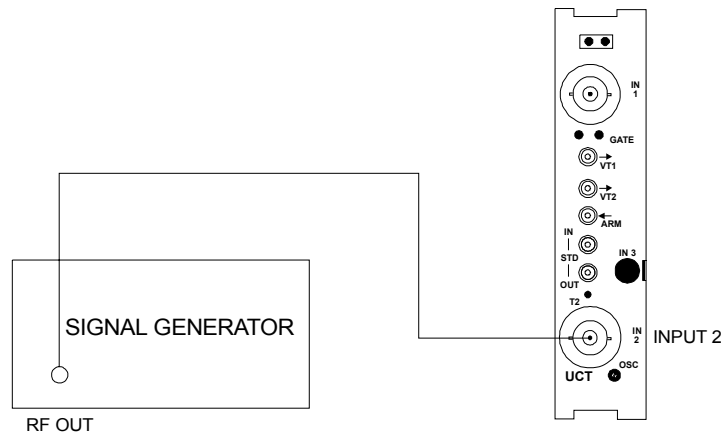

Figure 6-8, Input 2 Filter Check Configuration

Set the generator to 50kHz, 1Vrms. Check that the UCT is measuring 50kHz and the peak to peak signal level is:

Command Syntax	Notes
MEAS2:FREQ?	Confirm 50kHz
MEAS2:VOLT:MAX?	V_{P1}
MEAS2:VOLT:MIN?	V_{N1}

Switch in the input filter for channel 2 and again check that the counter measures a frequency of 50kHz. Measure the peak to peak signal and verify that the signal amplitude is reduced by greater than 2dB.

INP1:FILT:LPAS:STAT ON	turn on LPF for channel 2
MEAS2:FREQ?	Confirm 50kHz
MEAS2:VOLT:MAX?	V_{P2}
MEAS2:VOLT:MIN?	V_{N2}

Use the equation :

$$20 * \log((V_{P1} - V_{N1}) / (V_{P2} - V_{N2})) > 2.0$$

or

$$((V_{P1} - V_{N1}) / (V_{P2} - V_{N2})) > 1.25$$

to verify compliance.

Input 1 Attenuator Check

Set the UCT to its default state. Select 50Ω impedance for Input 1.

Configure UCT as follows:

*RST	returns unit to default state
INP1:IMP 50	select 50Ω impedance for Input 1

Connect the UCT to the signal generator as shown in Figure 6-9.

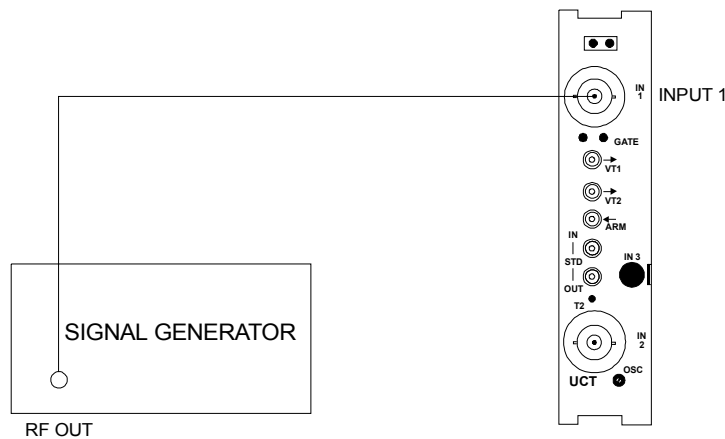

Figure 6-9, Input 1 X10 Attenuator Check Configuration

Set the signal generator to 1MHz, 10mV. Increase the signal generator output level until the UCT gives a stable reading. Note the signal generator output level.

Enable the UCT Input 1 attenuator and check that the UCT no longer counts. Increase the signal generator until the UCT gives a stable reading. Note the signal generator output level and check that this level is approximately ten times the level previously noted.

Disconnect the test equipment.

Input 2 Attenuator Check

Set the UCT to its default state. Select 50 Ω impedance for Input 2.

Configure UCT as follows:

*RST	returns unit to default state
INP2:IMP 50	select 50 Ω impedance for Input 2

Connect the UCT to the signal generator as shown in Figure 6-10.

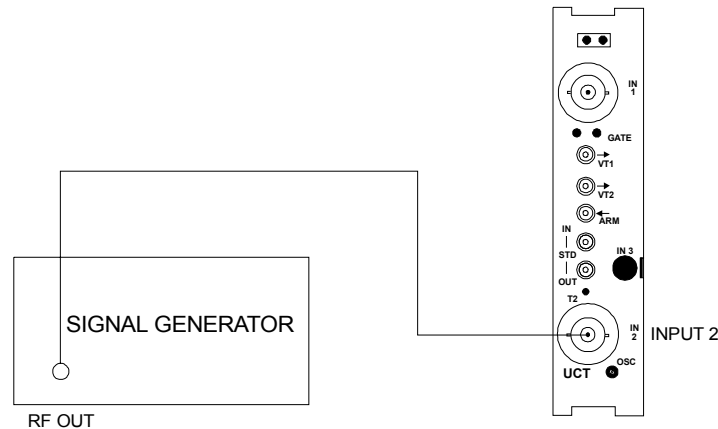

Figure 6-10, Input 2 X10 Attenuator Check Configuration

Set the signal generator to 1MHz, 10mV. Increase the signal generator output level until the UCT gives a stable reading. Note the signal generator output level.

Enable the UCT Input 2 attenuator and check that the UCT no longer counts. Increase the signal generator until the UCT gives a stable reading. Note the signal generator output level and check that this level is approximately ten times the level previously noted.

Disconnect the test equipment.

Hysteresis Check for Input 1

Set the UCT to its default state. Select 50 Ω impedance for Input 1.

Equipment: Signal Generator

Configure UCT as follows:

*RST	returns unit to default state
INP1:IMP 50	selects 50 Ω impedance

Set the signal generator to 10MHz, 15mV and apply to Input 1. Verify that the UCT has a stable reading. Enable Hysteresis for maximum and verify the UCT no longer counts. Increase the signal generator output level to 30mV and verify the UCT has a stable reading.

Command syntax:

INP1:COMP:HYST:REL MAX	enables hysteresis
MEAS1:FREQ?	takes a measurement

Disconnect the test equipment.

Hysteresis Check for Input 2

Set the UCT to its default state. Select 50 Ω impedance for Input 2.

Equipment: Signal Generator

Configure UCT as follows:

*RST	returns unit to default state
INP2:IMP 50	selects 50 Ω impedance

Set the signal generator to 10MHz, 15mV and apply to Input 2. Verify that the UCT has a stable reading. Enable Hysteresis for maximum and verify the UCT no longer counts. Increase the signal generator output level to 30mV and verify the UCT has a stable reading.

Command syntax:

INP2:COMP:HYST:REL MAX	enables hysteresis
MEAS2:FREQ?	takes a measurement

Disconnect the test equipment.

Calibration, External Standard Output (2461-Ce and 2461-Cf)

Internal Frequency Standard Adjustment

1. Prior to calibration, the 2461-Ce or -Cf must be in continuous operation for 4 hours at an ambient temperature of $23 \pm 2^\circ\text{C}$.
2. Connect the master frequency standard (9480/FRS or equivalent) to INPUT 1 of the 2461-Ce or -Cf Frequency Counter.

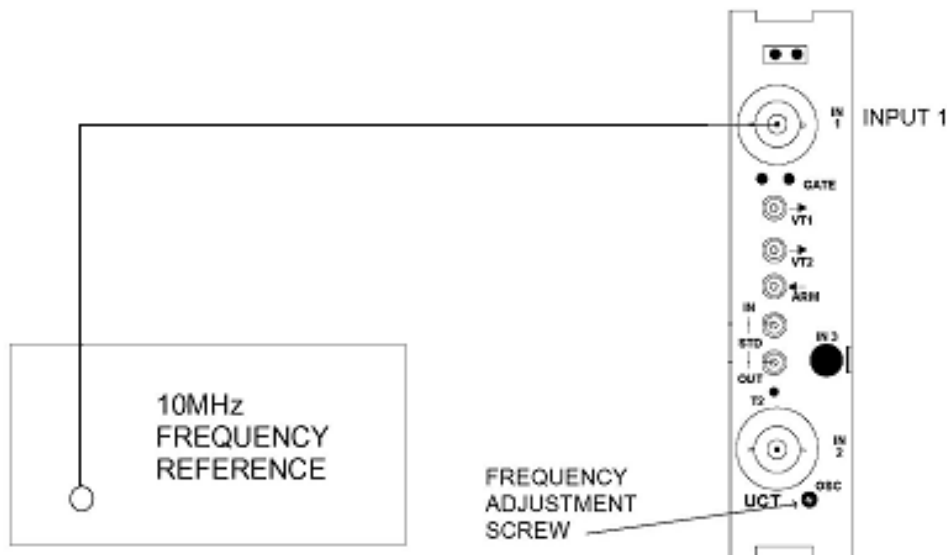

Figure 6-11, External Standard Output

3. Program the 2461-Cf Frequency Counter as follows using the Soft Front Panel or SCPI commands using a program like VIC or VISAIC:
 - a. Frequency, Channel 1, 10s gate time (CONF1:FREQ 10e6,10)
 - b. AC coupled 50 ohm input impedance (INP1:COUP AC;IMP 50)
 - c. Auto-Trigger (INP1:COMP:SET:AUTO)
 - d. Select internal standard (SOUR:ROSC INT)
4. Use a small screwdriver to adjust the Frequency Adjust Screw until a reading of $+10.00000000e+06$ is reached. Use READ? to take a reading.

5. Allow the reading to stabilize for 5 minutes and re-adjust to the following tolerances:
TCXO: 1 Hz
OCXO: 0.1 Hz

This page was left intentionally blank.

Chapter 7

PRODUCT SUPPORT

Product Support

Racal Instruments has a complete Service and Parts Department. If you need technical assistance or should it be necessary to return your product for repair or calibration, call 1-800-722-3262. If parts are required to repair the product at your facility, call 1-949-859-8999 and ask for the Parts Department.

When sending your instrument in for repair, complete the form in the back of this manual.

For worldwide support and the office closes to your facility, refer to the Support Offices section on the following page.

Reshipment Instructions

Use the original packing material when 2461Type C card to Racal Instruments for calibration or servicing. The original shipping crate and associated packaging material will provide the necessary protection for safe reshipment.

If the original packing material is unavailable, contact Racal Instruments Customer Service for information.

Support Offices RACAL INSTRUMENTS

United States

(Corporate Headquarters and Service Center)
4 Goodyear Street, Irvine, CA 92618
Tel: (800) 722-2528, (949) 859-8999; Fax: (949) 859-7139

5730 Northwest Parkway Suite 700, San Antonio, TX 78249
Tel: (210) 699-6799; Fax: (210) 699-8857

Europe

(European Headquarters and Service Center)
18 Avenue Dutartre, 78150 LeChesnay, France
Tel: +33 (0)1 39 23 22 22; Fax: +33 (0)1 39 23 22 25

29-31 Cobham Road, Wimborne, Dorset BH21 7PF, United Kingdom
Tel: +44 (0) 1202 872800; Fax: +44 (0) 1202 870810

Via Milazzo 25, 20092 Cinisello B, Milan, Italy
Tel: +39 (0)2 6123 901; Fax: +39 (0)2 6129 3606

Technologie Park, Friedrich Ebert Strasse, 51429 Bergisch Gladbach, Germany
Tel: +49 (0) 2204 844200; Fax: +49 (0) 2204 844219

REPAIR AND CALIBRATION REQUEST FORM

To allow us to better understand your repair requests, we suggest you use the following outline when calling and include a copy with your instrument to be sent to the Racal Repair Facility.

Model _____ Serial No. _____ Date _____

Company Name _____ Purchase Order # _____

Billing Address _____

City

State/Province

Zip/Postal Code

Country

Shipping Address _____

City

State/Province

Zip/Postal Code

Country

Technical Contact _____ Phone Number () _____

Purchasing Contact _____ Phone Number () _____

1. Describe, in detail, the problem and symptoms you are having. Please include all set up details, such as input/output levels, frequencies, waveform details, etc.

2. If problem is occurring when unit is in remote, please list the program strings used and the controller type.

3. Please give any additional information you feel would be beneficial in facilitating a faster repair time (i.e., modifications, etc.)

4. Is calibration data required? Yes No (please circle one)

Call before shipping

Note: We do not accept
"collect" shipments.

Ship instruments to nearest support office
listed on back.

This page was left intentionally blank.

Appendix A

Model 2461 Type C SPECIFICATIONS

WARNING

To ensure protection against electrical shock, the warnings detailed in the Safety Precautions page of the handbook must be observed.

Technical Specification

Channels 1 and 2 - Input Characteristics

Channels 1 and 2 are coupled via INPUT 1 and INPUT 2 respectively. These channels can be operated independently (SEPARATE mode) or with Channel 2 buffer amplifier input commoned with Channel 1 buffer amplifier input.

Frequency Range

Channel 1: DC to 200MHz

Channel 2: DC to 100MHz

Signal Routing

SEPARATE mode: INPUT 1 routed through Channel 1 buffer
INPUT 2 routed through Channel 2 buffer

COMMON mode: INPUT 1 routed to Channel 1 buffer and Channel 2 buffer

Input Impedance

×1 and ×10 Attenuation

INPUT 1 or 2 in SEPARATE mode: 1MΩ nominal shunted by ≤ 45pF
or
50Ω (DC coupled)

INPUT 1 in COMMON mode: 1M Ω nominal shunted by ≤ 55 pF
 or
 50 Ω (DC coupled)

Sensitivity

$\times 1$ attenuation

Sinewave:

$10\text{Hz} \leq f \leq 100\text{MHz}$	25mV RMS
$100\text{MHz} < f \leq 160\text{MHz}$	50mV RMS
$160\text{MHz} < f \leq 200\text{MHz}$	75mV RMS

where: f is the input frequency in Hz

Pulse:

75mV for pulse widths down to 5ns

Variable Sensitivity (Hysteresis)

Two selectable settings of the hysteresis level allow the sensitivity to be adjusted. The above Sensitivity figures are with the hysteresis in its most sensitive position, but the sensitivity will be reduced by a factor of 2 nominal upon selecting the other setting.

Dynamic Range

$\times 1$ attenuation:

$10\text{Hz} \leq f \leq 50\text{MHz}$	5Vpk-pk min.
$50\text{MHz} < f \leq 160\text{MHz}$	2.5V pk-pk min.
$160\text{MHz} < f \leq 200\text{MHz}$	1.5Vpk-pk min.

$\times 10$ attenuation:

$10\text{Hz} \leq f \leq 50\text{MHz}$	50Vpk-pk min.
$50\text{MHz} < f \leq 160\text{MHz}$	25Vpk-pk min.
$160\text{MHz} < f \leq 200\text{MHz}$	15Vpk-pk min.

where: f is the input frequency in Hz)

Signal Operating Range

$\times 1$ attenuation: -5.1VDC to +5.1VDC

Input Attenuation

×1 or ×10 selectable.

Coupling

AC or DC

Damage Level (AC or DC)

(CAUTION)

1MΩ (×1):

DC ≤ f ≤ 2kHz 260V (DC + AC RMS)

2kHz < f ≤ 100kHz $\frac{5 \times 10^5}{f}$ V RMS

f > 100kHz 5V RMS

1MΩ (×10):

DC ≤ f ≤ 20kHz 260V (DC + AC RMS)

20kHz < f ≤ 100kHz $\frac{5 \times 10^6}{f}$ V RMS

f > 100kHz 50V RMS

50Ω (×1 & ×10):

DC ≤ f ≤ 200MHz 5V (DC + AC RMS)

(where f is the input frequency in Hz)

WARNING

To ensure protection against electrical shock, the warnings detailed on the Safety Precautions page of this handbook must be observed.

Low Pass Filter

Independently selectable in Channel 1 and Channel 2.

3dB bandwidth:	50kHz nominal
Attenuation rate:	20dB per decade nominal

Input Connection

BNC female

Crosstalk

> 36dB separation between channels 1 & 2

(measured at 100MHz in a 50Ω system, ×1 attenuation).

Trigger Slope

Independently selectable positive or negative.

Manual Trigger

(1) Trigger Level Range -5.1V to +5.1VDC

(2) Trigger Level Resolution

x1 attenuation	2.5mV nominal
x10 attenuation	25mV nominal

(3) Trigger Level Accuracy
(Relative to the trigger point as queried with INP[1|2]:COMP:LEV?)

×1	± 1% reading ± 30mV
×10	± 1% reading ± 300mV

(4) Trigger Level Output

Independent buffered outputs representing the trigger level.

Range: ±5.1VDC irrespective of attenuator setting. For X10 the measured output voltage should be scaled by a factor of 10.

Resolution: 2.5mV nominal.

Accuracy:

(Relative to the trigger point as queried with INP[1|2]:COMP:LEV?)

x1 (Measured output not scaled by user)	$\pm 1\%$ setting $\pm 10\text{mV}$
x10 (Measured output scaled by user)	$\pm 1\%$ (setting $\times 10$) $\pm 100\text{mV}$

Output Impedance: 10 k Ω nominal.

Connector: MCX female jacks for both Channel 1 and 2 trigger level outputs. Outputs are labelled VT1 for Channel 1 and VT2 for Channel 2.

Automatic Trigger

In the automatic trigger mode the maximum and minimum values of the input waveform are measured and the trigger points are set nominally halfway between these values. The peak values are available via the DMM function.

The input signal must be continuously repetitive and be $\geq 5\text{ns}$ (pulse) or $\leq 20\text{MHz}$ sine wave. The UCT will also auto-trigger to a DC level (i.e. any signal with an AC content of $< 150\text{mV}$ pk-pk). In this case, the processor will return zero for the peak values and will set the trigger level to the nominal DC voltage at the input. The lowest frequency of auto-trigger can be set to 50Hz or 1kHz in order to minimize auto-trigger acquisition times.

Selectable Auto-Trigger Minimum Frequency

The auto-trigger algorithm is optimised for the lowest AC frequency to be acquired. In general, the lower the frequency that the algorithm has to process, the longer will be the maximum and typical acquisition times. For this reason, the user is given the ability to program the lowest input frequency that must be acquired, thereby reducing to a minimum the auto-trigger acquisition time. The algorithm will accept a programmable lower acquisition frequency of 50Hz or 1kHz (note that a lower limit of more than 1kHz would provide no further reduction in maximum or typical acquisition times). The following table shows how acquisition time is affected by input frequency. The default setting is 1kHz.

Minimum Input Frequency Set	Actual Input Frequency	Maximum Acquisition Time	Typical Acquisition Time
50Hz	50Hz	13s	---
50Hz	1kHz	---	2s
1kHz	1kHz	1.5s	---
1kHz	20MHz	---	0.4s

Auto Attenuation

The auto-trigger selects the appropriate attenuator automatically, and the following conditions apply:

×1 Attenuation:	Selected if positive and negative peak amplitudes are less than ±4.6V and the peak to peak amplitude of the signal does not exceed 4.4V.
×10 Attenuation:	Selected if positive or negative peak amplitudes are greater than ±5.1V or the peak to peak amplitude of the signal exceeds 5.1V.

Auto-Trigger Minimum Amplitude

150mV pk-pk.

Auto-Trigger Level Accuracy

(Relative to true trigger point)

×1	±30mV ± 1% of trigger level reading.
×10	±300mV ± 1% of trigger level reading.

Frequency 1 or 2

Range

Channel 1 6 x 10⁻⁴Hz to 200MHz (Prescaled by 2)

Channel 2 6 x 10⁻⁴Hz to 100MHz

LSD Displayed

$$\text{LSD} = F \times 10^{-D}$$

Where: D = Number of digits selected.
 F = frequency rounded to nearest decade.

Resolution

(selectable between 3 and 10 digits.)

For 3 to 5 Digits:

$$\text{Resolution} = \pm \text{LSD} \pm \frac{1.4 \times \text{TriggerError} \times \text{Frequency}}{\text{GateTime}} \quad (\text{subject to Notes (i) and (ii)})$$

For 6 to 10 Digits:

$$\text{Resolution} = \pm (2 \times \text{LSD}) \pm \frac{1.4 \times \text{TriggerError} \times \text{Frequency}}{\text{GateTime}} \quad (\text{subject to Notes (i) and (ii)})$$

BEST CASE RESOLUTION

The following calculations are based upon the assumption that the only contribution to the input noise is that of the input amplifier. Figures shown are for 9 digits selected (i.e. nominal gate time = 1s) with sinewave input.

Table 1.1 Frequency 1 - Best Case Resolution (Hz)

Input Frequency	Input Level			
	50mV RMS	100mV RMS	500mV RMS	1V RMS
10Hz	0.0005	0.0003	0.00005	0.00003
100Hz	0.0005	0.0003	0.00005	0.00003
1kHz	0.0005	0.0003	0.00005	0.00003
10kHz	0.0005	0.0003	0.00007	0.00005
100kHz	0.0007	0.0005	0.0003	0.0002
1MHz	0.003	0.002	0.002	0.002
10MHz	0.02	0.02	0.02	0.02
100MHz	0.2	0.2	0.2	0.2

Accuracy

$$\pm \text{Resolution} \pm \text{Timebase Error} \times \text{Frequency}$$

Period 1 or Period 2(Period Average)

Range

Channel 1 5ns to 1.7×10^3 s

Channel 2 10ns to 1.7×10^3 s

LSD Displayed

$$\text{LSD} = P \times 10^{-D}$$

Where: D = Number of digits selected
P = Period rounded up to next decade

Resolution

3 to 5 Digits:

$$\text{Resolution} = \pm \text{LSD} \pm \frac{1.4 \times \text{TriggerError} \times \text{Period}}{\text{GateTime}} \quad (\text{subject to Notes (i) and (ii)})$$

6 to 10 Digits:

$$\text{Resolution} = \pm(2 \times \text{LSD}) \pm \frac{1.4 \times \text{TriggerError} \times \text{Period}}{\text{GateTime}} \quad (\text{subject to Notes (i) \& (ii)})$$

Accuracy

$$\pm \text{Resolution} \pm \text{Timebase Error} \times \text{Period}$$

Ratio 1/2

Function

Displays the ratio of the frequency at INPUT 1 to the frequency at INPUT 2, i.e. Frequency1/Frequency2 (1 divided by 2).

Ratio Range

Frequency 1 and frequency 2 can each be in the range 6×10^{-4} Hz to 100MHz.

LSD

For 6-10 digits selected:

$$\frac{10}{\text{Frequency2} \times \text{GateTime}} \quad (\text{Rounded to nearest decade}) \quad (\text{Subject to Notes (i) and (ii)})$$

For 3-5 digits selected:

As above; or Ratio $\times 10^{-(D+2)}$ (where D = Number of digits selected) whichever gives the lesser value.

Resolution

$$\frac{\pm \text{LSD} \pm (1.4 \times \text{Channel 2 Trigger Error})}{\text{GateTime}} \times \text{Ratio} \quad (\text{subject to Notes (i) \& (ii)})$$

Accuracy

\pm Resolution (higher frequency applied to INPUT 1)

Time Interval (Separate or Common)

Time Range

Common Mode	5ns to 8×10^5 s
Separate Mode	0ns to 8×10^5 s

Note: In separate mode, Stop can occur before Start by up to 2ns in order to ensure that 0ns is met.

Input Channels Commoned

START on Input 1
STOP on Input 1

Input Channels Separate

START on Input 1
STOP on Input 2
or
START on Input 2
STOP on Input 1

Trigger Slopes

Start: Positive or Negative

Stop: Positive or Negative

LSD

1ns

Resolution

$\pm \text{LSD} \pm 1\text{ns RMS} \pm \text{START TRIGGER ERROR}^{\text{ii}} \pm \text{STOP TRIGGER ERROR}^{\text{ii}}$

Accuracy

$\pm \text{RESOLUTION} \pm (\text{TIMEBASE ERROR} \times \text{TI}) \pm (\text{TRIGGER LEVEL TIMING ERROR}^{\text{iii}})$
 $\pm 2\text{ns (DIFFERENTIAL CHANNEL DELAY ERROR}^{\text{iv}})$

Pulse Width

Measurement Range

5ns to 20ms

Input Channel

INPUT 1

Minimum Pulse Height

150mV pk-pk

Trigger Slopes

Positive Pulse:

START:	Positive
STOP:	Negative

Negative Pulse:

START:	Positive
STOP:	Negative

Trigger Point

START: 50% of measured pk-pk

STOP: 50% of measured pk-pk

LSD

1ns (100ps with averaging)

Resolution

$\pm \text{LSD} \pm 1\text{ns RMS} \pm \text{START TRIGGER ERROR}^{\text{ii}} \pm \text{STOP TRIGGER ERROR}^{\text{ii}}$

Accuracy

$\pm \text{RESOLUTION} \pm (\text{TIMEBASE ERROR} \times W_p) \pm (\text{TRIGGER LEVEL TIMING ERROR}^{\text{iii}})$
 $\pm 2\text{ns (DIFFERENTIAL CHANNEL DELAY ERROR}^{\text{iv}})$

where W_p = measured pulse width

Rise/Fall Time

Measurement Range

20ns to 20ms

Input Channel

INPUT 1 commoned with INPUT 2

Minimum Pulse Height

500mV pk-pk

Minimum Pulse Width

20ns at signal peaks

Rise Time Trigger Points

START on +ve slope at 10% of measured pk-pk

STOP on +ve slope at 90% of measured pk-pk

Fall Time Trigger Points

START on -ve slope at 90% of measured pk-pk

STOP on -ve slope at 10% of measured pk-pk

LSD

1ns (100ps with averaging)

Resolution

$\pm \text{LSD} \pm 1\text{ns RMS} \pm \text{START TRIGGER ERROR}^{\text{ii}} \pm \text{STOP TRIGGER ERROR}^{\text{ii}}$

Accuracy

Risetime: $\pm \text{RESOLUTION} \pm (\text{TIMEBASE ERROR} \times \text{Tr}) \pm (\text{TRIGGER LEVEL TIMING ERROR}^{\text{iii}}) \pm E_{10} \times \text{SR}_{\text{ST}}^{\text{iii}} \pm E_{90} \times \text{SR}_{\text{SP}}^{\text{iii}} \pm 2\text{ns (DIFFERENTIAL CHANNEL DELAY ERROR}^{\text{iv}})$

Fall Time: $\pm \text{RESOLUTION} \pm (\text{TIMEBASE ERROR} \times \text{Tf}) \pm (\text{TRIGGER LEVEL TIMING ERROR}^{\text{iii}}) \pm E_{10} \times \text{SR}_{\text{ST}}^{\text{iii}} \pm E_{90} \times \text{SR}_{\text{SP}}^{\text{iii}} \pm 2\text{ns (DIFFERENTIAL CHANNEL DELAY ERROR}^{\text{iv}})$

where: Tr = measured Rise Time
Tf = measured Fall Time
E₁₀ = Error in measuring the 10% point
E₉₀ = Error in measuring the 90% point

Notes and Definitions

Note (i) - Resolution/Gate Time

In FREQUENCY, PERIOD, RATIO and CHECK modes, the gate time is set by the resolution selected. However the gate time will be extended by up to:

One period of the input signals on FREQUENCY 2, PERIOD 2, RATIO 1/2.
Two periods of the input signal on FREQUENCY 1, PERIOD 1.

The resolution of PHASE and TOTALIZE measurements is determined by the input signal.

Measurements of TIME INTERVAL, RATIO, PULSE WIDTH and RISE/FALLTIME have resolution determined by both the input signal and the resolution set.

Selected number of digits in Frequency, Period and Check ^(a)	Gate Time
10	10s
9	1s
8*	100ms
7	10ms
6	1ms
5	1ms ^(b)
4	1ms ^(b)
3	1ms ^(b)

* initialized state

Note: a) To avoid unnecessary shifting of digits, the MSD is allowed to exceed the resolution by 1 digit for a 10% over range.

b) Measurement of FREQUENCY, PERIOD, RATIO and CHECK are averaged when these number of digits are selected.

Note (ii) - Trigger Error

$$\text{Err}_{\text{trig}} = \frac{\sqrt{e_i^2 + e_n^2}}{S_{\text{trig}}} \quad \text{seconds RMS}$$

Where: Err_{trig} = Trigger Timing Error in seconds RMS.
 e_i = input amplifier RMS noise (typically 170 μ V RMS in 200MHz bandwidth).
 e_n = input signal RMS noise in 200MHz bandwidth.
 S_{trig} = slew rate of input signal at trigger point.

Note (iii) - Trigger Level Timing Error (×1 attenuation)

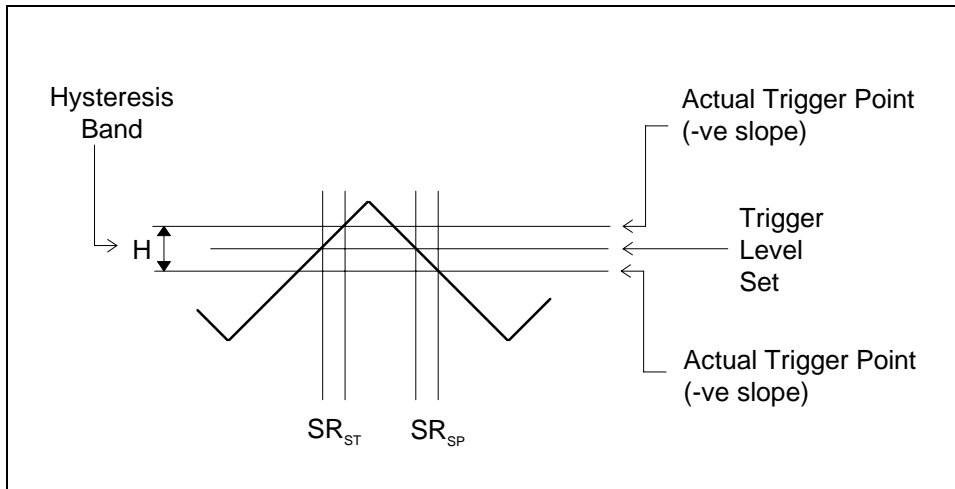

$$Err_{TLT} = \frac{H}{2} \times \left(\frac{1}{SR_{ST}} - \frac{1}{SR_{SP}} \right)$$

where: Err_{TLT} = Trigger Level Timing Error (seconds)
 H = peak to peak hysteresis band (typically 20mV for high sensitivity setting
 typically 40mV for low sensitivity setting.
 all figures at +23°C)
 SR_{ST} = Slew Rate of input signal at START
 SR_{SP} = Slew Rate of input signal at STOP

Note (iv) - Differential Channel Delay Error

This is an internal systematic error which is typically less than 1ns and can be compensated for by numerical offset (MATH) or by adjusting cable lengths.

Totalizing 1 By 2

Input Channel

INPUT 1 (max. frequency 100MHz)

Maximum Rate

10^8 events per second

Range1 to $(10^{12} - 1)$ **Pulse Width**

5ns minimum at actual trigger points

Electrical Start/Stop

Channel 2:

INPUT2 Slope	START	STOP
POSITIVE	↑	↓
NEGATIVE	↓	↑

Accuracy ± 1 count.**Manual Start Stop 1**

By means of a SCPI command or a button on the soft front panel of the *VXIplug&play* driver (Racal Instruments Part No. 60-0087).

Totalizing 2 By 1**Input Channel**

INPUT 2 (max. frequency 100MHz)

Maximum Rate 10^8 events per second

Range

1 to $(10^{12} - 1)$

Pulse Width

5ns minimum at actual trigger points

Electrical Start/Stop

Channel 2:

INPUT1 Slope	START	STOP
POSITIVE	↑	↑
NEGATIVE	↓	↓

Accuracy

± 1 count.

Manual Start Stop 1

By means of a SCPI command or a button on the soft front panel of the VXI *plug&play* driver (RIL Part No. 60-0087).

Phase 1 Relative to 2

To make this relative phase measurement, the UCT first makes a series of measurements in different modes:

- (1) Ratio 1/2 to ensure that 1 and 2 are at the same frequency.
- (2) Period 1 (P_1).
- (3) Time Interval 1 to 2 ($TI_{1,2}$).

The phase difference Φ_{1-2} is then calculated as follows:

$$\Phi_{1-2} = \frac{TI_{1-2}}{P_1} \times 360^\circ$$

Phase Range

0.1 ° to 360 °

LSD

$F_{in} \leq 1\text{MHz}$:	0.1 °
$1\text{MHz} < F_{in} \leq 10\text{MHz}$:	1 °
$10\text{MHz} < F_{in} \leq 100\text{MHz}$:	10 °

Resolution

$$\pm \text{LSD} \pm \frac{\text{TI Resolution}}{\text{Period1}} \times 360^\circ$$

Accuracy

$$\pm \text{LSD} \pm \frac{\text{TI Accuracy}}{\text{Period1}} \times 360^\circ$$

- Note:**
- (1) A constant signal is required during a phase measurement.
 - (2) A phase measurement will nominally take 160ms at 100MHz and 4s at 1Hz.

Phase 2 Relative to 1

To make this relative phase measurement, the UCT first makes a series of measurements in different modes:

- (1) Ratio 2/1 to ensure that 2 and 1 are at the same frequency.
- (2) Period 2 (P_2).
- (3) Time Interval 2 to 1 (TI_{2-1}).

The phase difference Φ_{2-1} is then calculated as follows:

$$\Phi_{2-1} = \frac{TI_{2-1}}{P_2} \times 360^\circ$$

Phase Range

0.1° to 360°

LSD

$F_{in} \leq 1\text{MHz}$: 0.1°

$1\text{MHz} < F_{in} \leq 10\text{MHz}$: 1°

$10\text{MHz} < F_{in} \leq 100\text{MHz}$: 10°

Resolution

$$\pm \text{LSD} \pm \frac{\text{TI Resolution}}{\text{Period}^2} \times 360^\circ$$

Accuracy

$$\pm \text{LSD} \pm \frac{\text{TI Accuracy}}{\text{Period}^2} \times 360^\circ$$

- Note:** (1) A constant signal is required during a phase measurement.
- (2) A phase measurement will nominally take 160ms at 100MHz and 4s at 1Hz.

DVM Function

The instrument is able to measure the positive peak, the negative peak, or the DC voltage of signals applied to IN1 or IN2. To do this it makes use of the auto-trigger capabilities.

Positive (MAX) or negative (MIN) Peak

Peak Measurement Range:

-51V to +51V
(x1 or 10 attenuation automatically selected as necessary)

Minimum Amplitude:

150mV peak to peak

LSD:

0.5mV

Resolution:

x1 $\pm 2.5\text{mV nominal}$
x10 $\pm 25\text{mV nominal}$

Accuracy:

x1 $\pm 6\%V_{\text{pk-pk}} \pm 50\text{mV}$
X10 $\pm 10\%V_{\text{pk-pk}} \pm 500\text{mV}$
 where $V_{\text{pk-pk}}$ is the Peak to Peak measurement

DC Value (MID)

This function returns a value equal to the mean perceived peak values. If AC content is below 150mV pk-pk then the perceived DC voltage is returned.

Measurement Range:

-51V to +51V
(x1 or 10 attenuation automatically selected as necessary)

LSD:

0.5mV

Resolution:

x1 $\pm 2.5\text{mV nominal}$
x10 $\pm 25\text{mV nominal}$

Accuracy:

x1 $\pm 6\%V_{\text{MID}} \pm 50\text{mV}$
x10 $\pm 10\%V_{\text{MID}} \pm 500\text{mV}$
 where V_{MID} is the measured value.

Time Interval Delay

Hold off Time

0.2 to 1.048576s

Step Size

16 μ s

Accuracy

$\pm 50\mu\text{s} \pm 0.1\%$ reading.

Note: The delay is also available on Input 2 when totalizing.

Read Rate

Frequency Measurements:

43 readings per second max. under the following conditions:

Resolution ≤ 6 digits, continuous trigger, auto-trigger OFF (both channels), input freq. $\geq 10\text{kHz}$.

Time Interval Measurements:

43 readings per second max. under the following conditions:

Resolution ≤ 6 digits, continuous trigger, auto-trigger OFF (both channels), input freq. $\geq 10\text{kHz}$., TI $\leq 1\text{ms}$

Averaging

This user selectable function can give improved resolution.

Number of Samples: 100

Availability:

Frequency 1
 Frequency 2
 Period 1
 Period 2
 Ratio 1/2
 Ratio 2/1
 Time Interval 1 to 2
 Time Interval 2 to 1
 Rise Time
 Fall Time
 Positive Pulse Width
 Negative Pulse Width
 Phase 1 relative 2
 Phase 2 relative 1

Resolution Improvement: The resolution obtained with these functions will be 1 digit more than without averaging selected. The maximum resolution available remains at 10 digits.

Minimum LSD on Time Interval: 0.1ns

Math Function

The following algorithm can be invoked:

$$\frac{(result - offset)}{scale}$$

Permitted ranges of values for *offset* and *scale*: 0, 10×10^{-9} to 10×10^9 ,
 -1×10^{-9} to -10×10^9

Permitted number of significant figures: 9

Display Range: $9.99999999 \times 10^{\pm 9}$ to $-9.99999999 \times 10^{\pm 9}$

- Note:**
- (1) Any number exceeding the allowed range for Offset or Scale will result in an error being reported.
 - (2) Any number exceeding the display range will result in an error being reported.
 - (3) The Math Function is not available on CHECK, PHASE , PULSE WIDTH, RISE/FALLTIME, READ MID, READ MAX, READ MIN.

Frequency Standard

The UCT requires a 10MHz frequency standard in order to function. This can be derived from the VXI 'CLOCK10' (generated by the SLOT0 controller), from an external 10MHz standard connected to the front panel, or from an optional internally installed TCXO or OCXO. The default setting is 'CLK10'. A buffered version of the standard in use is available at the front panel 'STD OUT' connector.

Internal Standard Output

Frequency:	10MHz
Output Configuration	LSTTL with 47 Ω Series resistor.
Drive Level:	V_{OH} 2.6V min. at -400 μ A V_{OL} 0.6V max. at 8mA The output is also capable of driving 1Vpk-pk min, into 50 Ω
Maximum Reverse Input: (CAUTION)	Tested to $\pm 5V$ without damage.
Connector:	MCX female

External Standard Input

Frequency:	10MHz
Signal Level:	100mV RMS sinewave minimum, 10V RMS maximum.
Maximum Input Level: (CAUTION)	10VRMS, or +15V or -15V peak..
Input Impedance:	1k Ω nominal for signals less than 1Vpk-pk decreasing to 500 Ω nominal for signals 10Vpk-pk and above.
Coupling:	AC
Connector:	MCX female

External Arming

All functions (with the exception of phase) can be armed by means of an EXT ARM input connector. The various modes can be selected via special functions.













External Arming Sources

'EXT ARM' input (front panel); VXI 'TTLTrig0-7' (user selectable).

EXT ARM Input

Input Impedance:	1 k Ω nominal
Coupling:	DC
Input Levels:	
Vil maximum	0.4V
Vih minimum	2.4V
Maximum Input Level: (CAUTION)	10V RMS, or +15V or -15V peak
Connector:	MCX female

ARM Modes

Mode	Start	Stop
1	SELF ARM	SELF ARM
2		SELF ARM
3		SELF ARM
4	SELF ARM	
5	SELF ARM	
6		
7		
8		
9		

Timing Requirements

Minimum START to STOP Time: 200ns

Resolution

This is set as follows:

External Gate Time Start to Stop:

GATE TIME (Tg)	No. of Meaningful Digits Returned
Tg < 100 μ s	4
Tg < 1ms	5
Tg < 10ms	6
Tg < 100ms	7
Tg < 1s	8
Tg < 10s	9
Tg > 11s	10 (maximum available)

Gate Output

The measurement gate pulse can be made available (user selectable) on any one of the VXI trigger lines TTLTrig0 to 7, or on none of these.

Front Panel Components

Indicators:

Channel 1 Trigger LED

This amber LED flashes to indicate that Channel 1 is triggering.

Channel 2 Trigger LED

This amber LED flashes to indicate that Channel 2 is triggering.

Gate LED

This green LED lights when the measurement gate is open.

Access LED

This amber LED lights when there is a word serial command access.

Fail LED

This red LED (if permanently on) indicates a unit failure.

Connectors

LABEL	FUNCTION	TYPE
IN 1	Channel 1 input	BNC Female
IN 2	Channel 2 input	BNC Female
VT1	Channel 1 trigger voltage output	MCX Female
VT2	Channel 2 trigger voltage output	MCX Female
ARM	External ARM input	MCX Female
STD OUT	Standard in-use output	MCX Female
STD IN	External Standard input	MCX Female

Power Supply

Peak and Dynamic Module Current Contributions

VXI Supply Rail	One UCT with TCXO or OCXO*	
	I_{Pm} (A)	I_{Dm} (A)
+5V	.53	.03
+24V	.22	.01
-24V	.13	.01
-5.2V	.38	.06
-2V	0	0

*OCXO or TCXO contributes 65mA to I_{Pm} on +24V rail, negligible to I_{Dm}

Power Absorbed

Max. power absorbed: 13.03W (one UCT with TCXO or OCXO) function card
 17.3W for complete module (one function card + VXI Interface)

Environmental Conditions

- (1) Operating external ambient inlet temperature range when installed in host VXI module.
 With or without TCXO or OCXO: 0°C to +50°C
- (2) Non-operating ambient temperature range:
 With or without TCXO or OCXO: -40°C to +70°C
- (3) Relative Humidity (Operating): 65% non condensing to +40°C
- (4) Relative Humidity (Non-Operating) 93% non condensing
- (5) Operating Altitude 10,000 ft maximum
- (6) Non-Operating Altitude 15,000 ft maximum
- (7) Vibration / Drop **IEC 68-2-31**

(8)	Shock	IEC 68-2-29
(9)	MTBF	62,000 hours for a 2461 Type Ce (TCXO oscillator) Card 40,000 hours for a module with one 2461 Type Ce Card
(10)	MTTR	30 minutes (based on card replacement)
(11)	Cooling Requirements (10°C temp. rise)	
	Min. Flow Rate:	4l/s
	ΔP	0.14mmH ₂ O

Options

TCXO Frequency Reference

A temperature compensated frequency standard.

(1)	Frequency:	10MHz
(2)	Adjustment Range: Front panel electrical trim	$\pm 5 \times 10^{-6}$ minimum
(3)	Aging:	$\pm 1 \times 10^{-6}$ max. per year
(4)	Temperature Stability:	$\pm 1 \times 10^{-6}$ maximum with respect to the frequency at 25°C, over the op. range of the module.

Ovenized Oscillator

A temperature controlled frequency standard with higher stability than the TCXO.

(1)	Frequency:	10MHz
(2)	Adjustment Range: Front Panel electrical: Internal mechanical:	$\pm 2 \times 10^{-6}$ minimum $\pm 2 \times 10^{-6}$ minimum
(3)	Aging:	$\pm 1 \times 10^{-9}$ per day at shipment $\pm 1 \times 10^{-7}$ per year.
(4)	Warm-up:	$\pm 1 \times 10^{-6}$ within 45 seconds $\pm 1 \times 10^{-7}$ within 3 minutes.

- (5) Temperature Stability: $\pm 1 \times 10^{-7}$ max., with respect to the frequency at 25°C, over the operating range of the module).

Switch Matrix Interface Connections

To allow connections to an intramodule switch matrix card, internal connections are provided, installed in parallel with the following inputs:

INPUT 1,
INPUT 2,
EXT ARM

Option Map

The following table maps the installment of option-variable components against specific assembly and Option numbers.

TCXO X402	OCXO X401	Assembly No.	Option No.
NO	NO	19-3285	d
YES	NO	19-3287	e
NO	YES	19-3289	f

This page was left intentionally blank.

Appendix B

APPLICATION NOTES

Default Settings For Automatic Functions

The UCT VXI instrument features a number of automatic functions:

- Pulse Width (both negative and positive)
- Rise/Fall Time
- Phase.

The purpose of these automatic functions is to reduce the amount of code the user must send to the UCT in order to set up complex measurements. For each of these automatic functions there are a number of default settings, some of which can be changed and some of which are not changeable when the automatic functions are enabled. The default settings are those that the user would have to individually program if the UCT did not offer the automatic settings, and they are reflected into other settings as necessary.

The Automatic Function Commands

The device dependent commands and their functions (which automatically adopt the default settings) are as follows:

Command	Measurement Function
CONF:PWID	Positive Pulse Width, defined as the time between the 50 % amplitude point of the rising and falling edges of a waveform. See Figure 5-1.
CONF:NWID	Negative Pulse Width, defined as the time between the 50 % amplitude point of the falling and rising edges of a waveform. See Figure 5-1.
CONF:RTIM	Rise Time, defined as the time between the 10 % and 90 % amplitude points on the rising edge of a waveform. See Figure 5-2.
CONF:FTIM	Fall Time, defined as the time between the 90 % and 10 % amplitude points on the falling edge of a waveform. See Figure 5-2.

CONF1:PHAS Phase, calculated as a time interval measurement between the signals on Channel 1 and 2, scaled by the period on the reference channel and normalized for degrees.

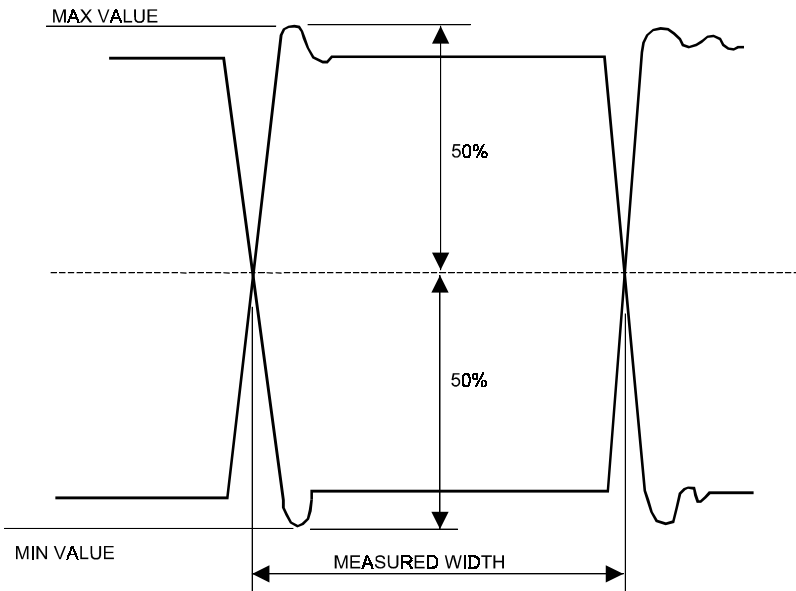

Figure 5-1, Positive/Negative Pulse

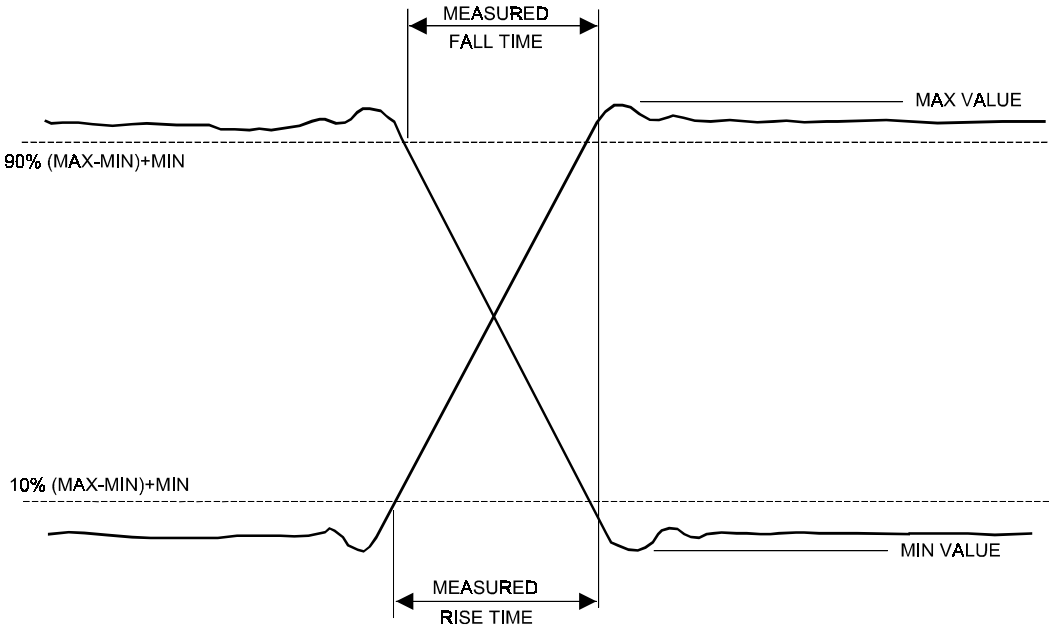

Figure 5-2, Rise/Fall Time

All of the the UCT automatic functions, except Phase, default to the following signal conditioning parameters:

Command	Measurement Function
INPUT1:ROUT COMMON	Common Channel 2 to Channel 1.
INPUT1:COMP:SETUP:AUOT ON	Auto-trigger Channel 1 (and Channel 2 due to Common mode).

When in the automatic functions of Pulse Width and Rise/Fall Time, the signal being measured on the UCT is on a single channel and the Common mode is automatically enabled. Channel 1 and 2 inputs are internally connected to allow the UCT to minimize propagation delay and mismatch. When in Common mode it is not possible to make measurements of INPUT2.

Output Format

Measurement data from the 2461 Type C function cards is always 18 characters long. The number is in engineering notation with a two digit exponent. The mantissa is right justified with leading zeros inserted to indicate resolution of measurement.

Pulse Width

The additional default settings applied when the Positive Pulse Width functions are selected are:

Command	Measurement Function
CONF1:TINT	Time Interval 1-2
INPUT1:COMP:SLOPE POS	Positive Slope, INPUT 1
INPUT2:COMP:SLOPE NEG	Negative Slope, INPUT 2

The following commands, when sent to the UCT while Positive Width is enabled, will generate an error:

Command	Measurement Function
INPUT1:COMP:SLOPE NEG	Attempt to change slope on INPUT 1.
INPUT2:COMP:SLOPE POS	Attempt to change slope on INPUT 2.
INPUT1:COMP:SETUP:AUTO OFF1ONCE	Attempt to change Auto trigger state on channel 1

INPUT1:ROUT SEP	Attempt to change to separate inputs
INPUT1:COMP:LEVEL	Attempt to set a trigger level
INPUT1:ATTEN	Attempt to change the attenuator

The default settings for Negative Pulse Width function, in addition to the above common settings, are:

Command	Measurement Function
CONF:TINT	Time Interval 1-2
INPUT1:COMP:SLOPE NEG	Negative Slope, INPUT 1
INPUT2:COMP:SLOPE POS	Positive Slope, INPUT 2

The following commands, when sent to the 2461 Type C while Negative Width is enabled will generate errors:

Command	Measurement Function
INPUT1:COMP:SLOPE POS	Attempt to change slope on INPUT 1.
INPUT2:COMP:SLOPE NEG	Attempt to change slope on INPUT 2.
INPUT1:COMP:SETUP:AUTO OFF/ONCE	Attempt to change Auto trigger state on 1/P1
INPUT1/2:COMP:LEVEL	Attempt to set a trigger level
INPUT1:ATTEN	Attempt to change the attenuator
INPUT1:ROUT SEP	Attempt to change to separate inputs

Rise/Fall Time

In addition to the above common settings, the default settings when the Rise Time function is selected are:

Command	Measurement Function
CONF1:TINT	Time Interval 1-2
INPUT1:COMP:SLOPE POS	Positive Slope, INPUT 1
INPUT2:COMP:SLOPE POS	Positive Slope, INPUT 2

The following commands, when sent to the 2461 Type C while Rise Time is enabled, will generate errors:

Command	Measurement Function
INPUT1:COMP:SLOPE NEG	Attempt to change slope on INPUT 1
INPUT2:COMP:SLOPE NEG	Attempt to change slope on INPUT 2
INPUT1:COMP:SETUP:AUTO OFF/ONCE	Attempt to change Auto trigger state on INPUT1
INPUT1:COMP:LEVEL	Attempt to set a trigger level on INPUT 1 & 2

INPUT1:ATTEN	Attempt to change attenuation state
INPUT1:ROUT SEP	Attempt to change to separate inputs

In addition to the above common settings, the default settings when the Fall Time function is selected are:

Command	Measurement Function
CONF1:TINT	Time Interval 1-2
INPUT1:COMP:SLOPE NEG	Negative Slope, INPUT 1
INPUT2:COMP:SLOPE NEG	Negative Slope, INPUT 2

The following commands, when sent to the 2461 Type C while Fall Time is enabled, will generate errors:

Command	Measurement Function
INPUT1:COMP:SLOPE POS	Attempt to change slope on INPUT 1
INPUT2:COMP:SLOPE POS	Attempt to change slope on INPUT 2
INPUT1:COMP:SETUP:AUTO OFF/ONCE	Attempt to change Auto trigger state on INPUT1
INPUT1/2:COMP:LEVEL	Attempt to set a trigger level on INPUT 1 & 2
INPUT1:ATTEN	Attempt to change attenuator state
INPUT1:ROUT SEP	Attempt to change to separate inputs

Phase Measurement

Phase measurement on the UCT is a sequence of functions, and is accomplished by measuring the time interval between the two signals and calculating the phase as a function of the total Period. This complex measurement is implemented as a series of three measurements:

- (1) A Ratio 1/2 or (2/1) to determine if the signals are the same frequency.
- (2) A Period measurement to determine the period of the reference signal.
- (3) A Time Interval measurement to determine the time difference between the two signals.

The Time Interval is then divided by the Period and the result multiplied by 360 to scale the answer for degrees. (Refer to Figure 5-3.)

$$(TI \div PER) \times 360$$

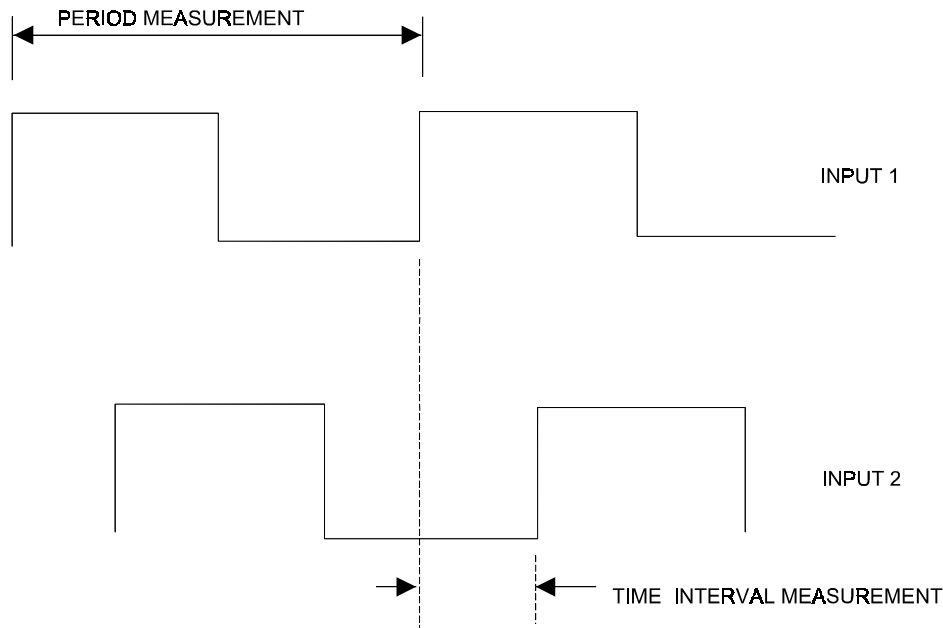

Figure 5-3, Phase Measurement

Summary

To summarize, the automatic functions are designed to reduce the user setup time by programming the 2461 Type C functions and signal conditioning parameters for typical values appropriate to the measurement. For example, most pulse parameter measurements are made on square waves or pulses, and the user would probably DC couple the input to avoid slowing down the signal and so changing its characteristics prior to measurement. Therefore, in Pulse Width and Rise/Fall Time modes, the 2461 Type C defaults to DC coupling.

Because of the default conditions and disallowed set-up parameters on the automatic functions of the 2461 Type C, care needs to be taken when designing drivers or soft panels to ensure that correct transitions are made when changing functions or changing signal conditioning parameters.